

dCS introduces
Bartók DAC

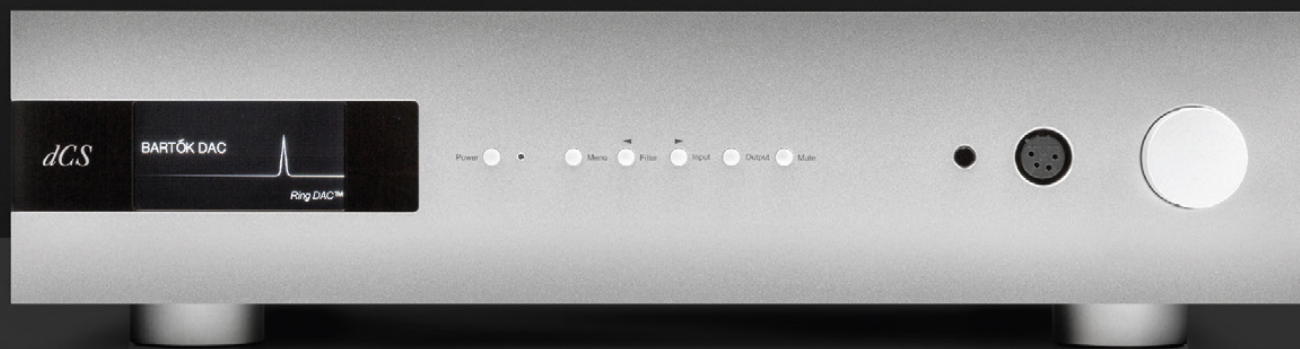

Stream or play your way



UPnP



TIDAL



SPOTIFY



ROON



AIRPLAY



MQA



USB

Available as a network streaming DAC or with optional Class-A headphone section as shown.

info@dcsLtd.co.uk | @dCSonlythemusic | www.dcsLtd.co.uk

Manufactured in the UK by Data Conversion Systems Ltd
Unit 1, Buckingham Business Park, Anderson Road, Swavesey, Cambridge, CB24 4AE

Imported by Data Conversion Systems Americas Inc. T +1 617 314 9296

dCS
ONLY THE MUSIC



T O N E

no. 96 June 2019

Luxmania!





Two 6" High-Definition Cast-Basket Bass/Midrange Drivers w/ Multi-Vaned Phase Plugs

Optimized Dual-Chamber Upper Bass/Midrange Enclosure with Angled Rear and Side Walls

High-Gauss High-Velocity Folded Ribbon Tweeter (HVFR™) w/Zobel Network

Open-Cell Polyurethane Foam Damping Pads

Proprietary Mix of Long-Fiber Lamb's Wool and Dacron for Internal Damping

Three 6" x 10" Quadratic Sub-Bass Drivers w/ Massive Focused-Field Magnet Structures

Elaborately Braced Accelerometer Optimized Non-Resonant Cabinet

Linear-Phase Balanced Crossover Network w/ Film Capacitors and Bridging Cap

Four Inertially-Balanced 10-1/4" x 9-1/2" Quadratic Planar Infrasonic Radiators

Two on Each Side of Cabinet

Hybrid Phase-Perfect Electronic/Passive Low Frequency Crossover

1800-Watt DSP-Controlled Class D Digital Amplifier with Programmable Logic Device Based State Machine

Elegantly Sleek Piano Gloss Black Lacquer Finish Cabinet

Massive 3/32" Thick Steel Plate Built Into the Base for Exceptional Structural Rigidity

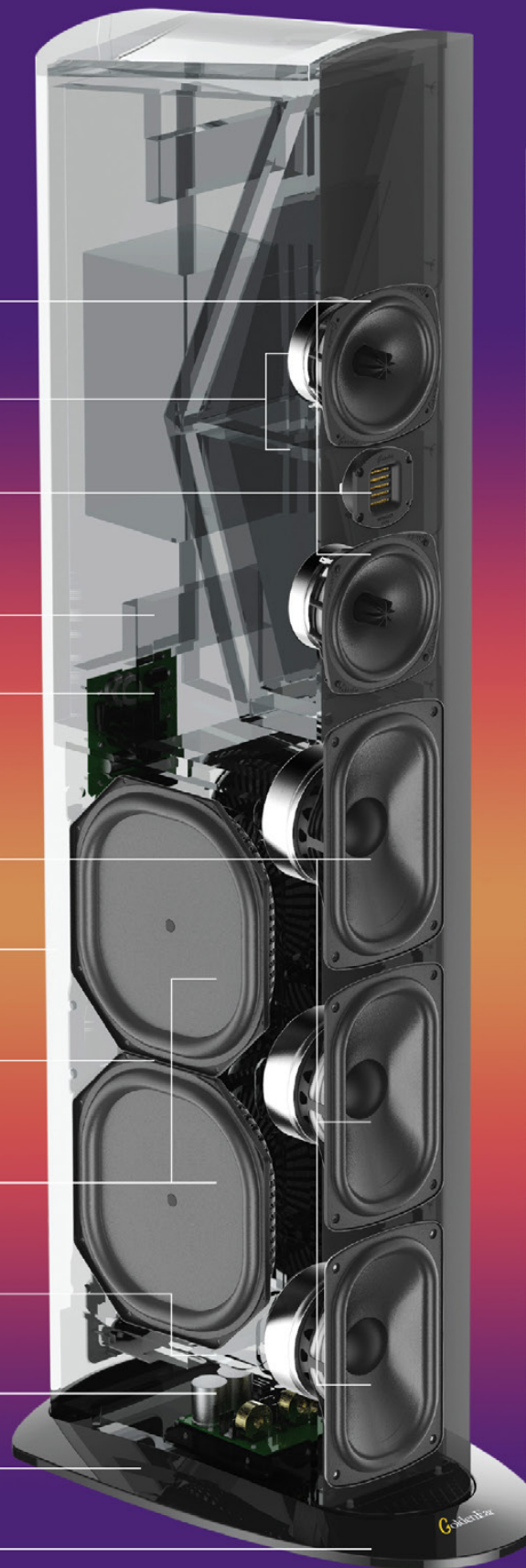

Triton Reference
\$4499 ea.

“GoldenEar’s New Triton Reference Redefines Ultra High-End Performance and Value!”

“Stunning...a completely new level of excellence...exceptional musical performance and an awesome anchor for a multi-channel or theater setup!”

– Jeff Dorgay, *Tone Audio*

“A remarkable amount of transparency, life and soundstage detail... fully competitive with some substantially more expensive speakers”

– Anthony Cordesman, *The Absolute Sound*

GoldenEar’s Triton One is one of the best selling high-end loudspeakers ever, consistently thrilling listeners and reviewers alike and winning an enviable and unmatched collection of the industry’s most prestigious awards, including “Loudspeaker-of-the-Year” and “Product-of-the-Year” from key publications all around the world.

Clearly, we knew that the One would be a very hard act to follow. There was a spirited discussion within our product development group about an all-out assault on the ultimate, cost-no-object, state-of-the-art, to produce a six-figure loudspeaker to do battle with the most esoteric and expensive loudspeakers on the planet. However, after much soul-searching, rational minds won out, and the decision was made to create a new GoldenEar flagship, positioned above the Triton One (of course still current and available), that would joust with the best, but still stick to our trademarked slogan, “We Make High-End Affordable.” We are pleased and proud to introduce the new Triton Reference. The Reference has begun gathering its own collection of honors, winning the prestigious and coveted CES Innovations Design and Engineering Award, Digital Trends Best Home Audio Tech at CES, HD GURU Best High Fidelity Loudspeaker at CES and What HiFi Stars of CES!

“Undeniably stellar... Yes, it does deliver the sort of performance previously delivered only by cost-no-object speakers.” – Dennis Burger, *Home Theater Review*

The Triton Reference is an evolution of everything that we have achieved with the Triton One, but taken to a stunning new level of sonic performance and sophisticated visual design. All the components in the T Ref: including larger, more powerful, active sub-bass drivers with huge “Focused Field” magnet structures, upper-bass/midrange drivers with “Focused Field” magnet structures, and High-Velocity Folded Ribbon tweeter with 50% more rare earth neodymium magnet material, are brand new, and have been specifically developed for use in the Reference. The powerful 1800 watt subwoofer amplifier, with level control to fine tune the bass to your room, and 56-bit DSP control unit are a significant evolution of those in the Triton One and our SuperSubs.

There are a myriad of other significant upgrades and refinements, including: new internal wiring with a specially developed twist, further development of our signature balanced crossover including

film capacitors bridged across the high-pass section on the upper-bass/midrange drivers, a unique proprietary mix of long-fiber lamb’s wool and Dacron for more effective internal damping, intensive work with a high-resolution accelerometer to determine the most effective implementation of complex internal bracing, a 3/32”-thick steel plate built into the medite base to further stiffen it for increased stability, new stainless steel floor spikes and cups, all of which results in higher resolution of subtle details... and the list goes on and on.

“The Triton Reference presents a serious challenge to speakers in the multi \$10K range”

– Robert Deutsch, *Stereophile*

Visually, the Reference offers a strikingly beautiful upgrade to the classic Triton styling, with a gorgeous hand-rubbed piano gloss-black lacquer finished one-piece monocoque cabinet. Sleek, statuesque and refined, the Reference is simply an elegantly gorgeous statement piece that will excite listeners with its dynamic visual presence, as well as its extraordinary sonic performance.

Sonically, the Reference has been engineered to perform with a dramatic and authoritative voice, comparable to speakers that sell for ten and more times its surprisingly affordable price. T Refs completely disappear, with superb three-dimensional imaging that will open up your room, stretching from wall to wall and beyond, and depth that makes the wall behind them seem to vanish. The astonishing bass is rock-solid, with low-frequency performance that is tight, quick, highly impactful and musical with extension flat to 20Hz and below. Another GoldenEar signature is a silky smooth high end that extends to 35 kHz with a lifelike sheen but no trace of fatiguing hardness, sibilance or stridency so common with lesser tweeters. Tremendous time and energy has been put into the voicing of the speaker and the seamless blending of the drivers, for unmatched musicality with all types of music, and home theater perfection. Rarely do speakers excel at both, but with their world-class neutrality, the Reference absolutely does. A special bonus is the Reference’s extremely high 93.25 dB sensitivity, which gives them tremendous dynamic range and allows use with almost any high-quality amplifier. You must experience T Ref for yourself!



www.goldenear.com

PO Box 141, Stevenson, MD 21153 (410) 998-9134

Like us on Facebook!
facebook.com/goldenear

Follow us on Twitter!
twitter.com/goldeneartech

Call us or check our website for your nearest dealer



In House

The soundtrack of assembling the issue...

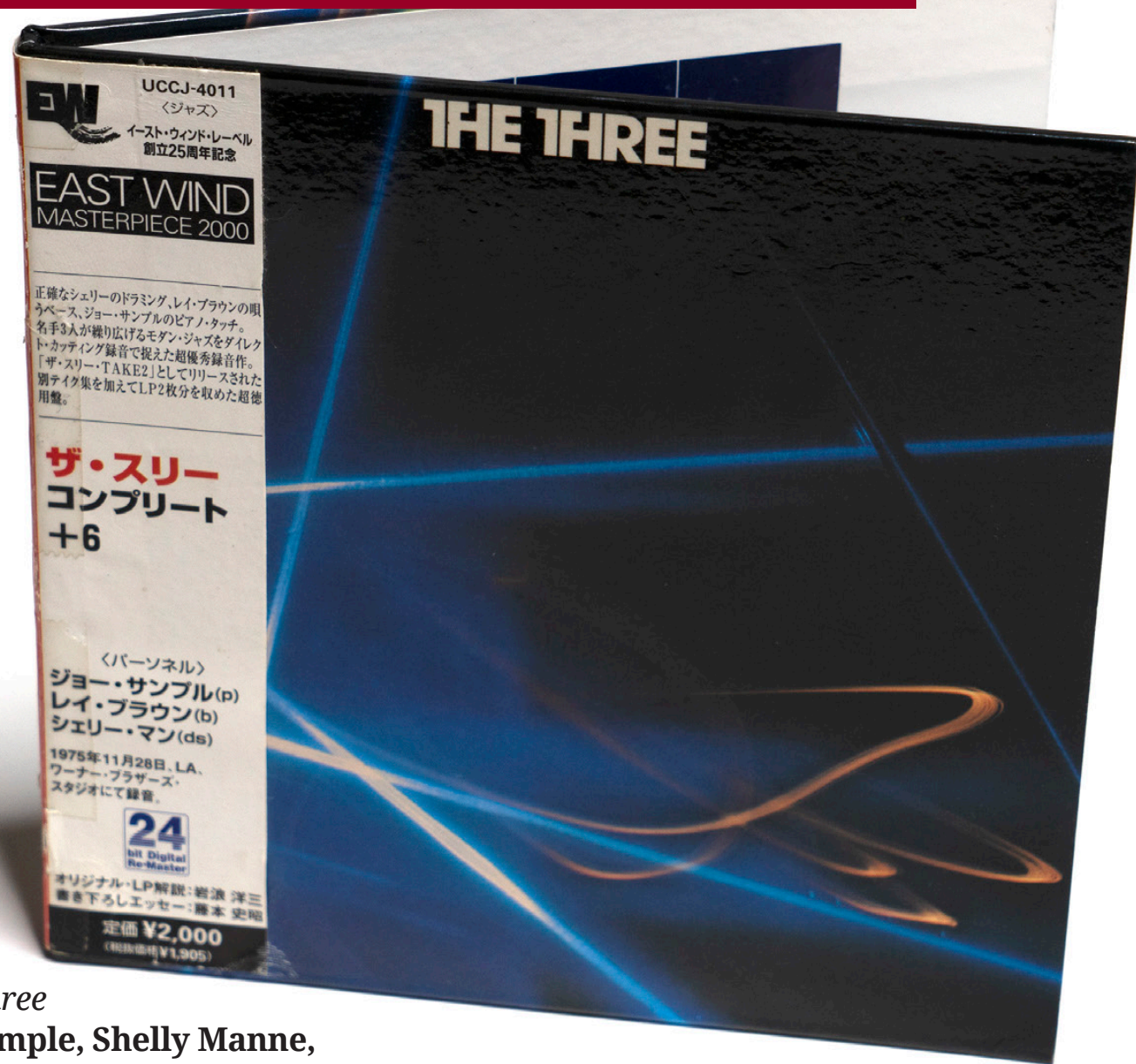

The Three
**Joe Sample, Shelly Manne,
Ray Brown**

While this is a rare Japanese CD copy, this was part of JVC's limited group of pressings to demonstrate the direct to disc recording process. Joe Sample, Ray Brown, and Shelly Manne put on a great performance here. A relaxing way to start a new issue.

INGENIUM PLUG&PLAY



AVAILABLE NOW
VISIT YOUR **AVID** DEALER

www.avidhifi.com



AVIDHIFI
MADE IN THE UK

Mofi ELECTRONICS

GET CLOSER TO THE
ORIGINAL MASTER RECORDING



Mobile Fidelity
UltraDeck Turntable



Isolated AC Synchronous Motor

UltraDeck's stepped-pulley 300RPM AC motor provides excellent speed stability for pitch accuracy and rhythmic drive.



Ultra Tonearm

The 10-inch straight, aluminum, gimbaled-bearing tonearm uses smooth ball bearings for low friction and Cardas Audio wiring to maintain complete signal purity.



Anti-Vibration Feet by HRS

Developed in conjunction with the engineers at Harmonic Resolution Systems, anti-vibration feet isolate UltraDeck from ruinous vibrations and interference.

Explore the full line at mofielectronics.com



T O N E

STAFF

Music Editor Jaan Uhelszki

Playlist Editor Roscoe Nicholson

Audio Historian Ken Kessler

Senior Contributor Rob Johnson

Analog Master Richard Mak

Administration Pamela Dorgay

Research Earle Blanton, Ken Mercereau, Scott Tetzlaff

Musicologist Tom Caselli

Information/Architecture Chris Kimmelshue

Art Director Brian Gage/Pipe & Tabor

Photography Jeff Dorgay

CONTRIBUTING WRITERS

Juan Cavillo

Emily Duff

Ben Fong-Torres

Brian Gage

Roy Hall

Michael "Muppet" Laurance

Andre Marc

Monique Meadows

Eric Neff

Jerold O'Brien

Gregory Petan

Shanon Swetlishnoff



Sigma 170 i Integrated Amplifier

Valve Amplification Company

www.vac-amps.com

©2018 Valve Amplification Company, Inc. VAC power amplifiers are protected by US Patent 8,749,310. International patents pending.

new arrivals...

Rob Sample, audio industry veteran joins our crew, but you won't see him in our pages. Watch for him joining our publisher on our upcoming video series, "Guilty Pleasures," Where we have heart to heart discussions about those records we're supposed to hate but secretly love.



"We're not worthy... we're not worthy!"

what's inside:

- 17 Publisher's Letter:**
What's what and who's who
- 50 Shannon Says...**
Shannon Swetishnoff tells us about upgrading the Gold Note PH10 phono stage
- 59 Welcome to MINE:**
Apple's latest HD Monitor
Carbon fiber from Brixton Forged
Keith Richards Box
The perfect Fez
And More!
- 90 Gear:**
Audio by VanAlstine SET400 Power Amplifier
Bryston 28B Power Amplifiers
Roon Nucleus Plus Music Server
Vitus Audio INT60 Integrated Amplifier with DAC
Nagra Classic Power Amplifier
- 118 Can't Get It Out of My Head**
Emily Duff
- 124 Setlist**
John Paul White plays Mississippi Studios
- 127 Future Tense:**
Reviews in process...



TONE

84

COVER STORY:

The Luxman C900u preamplifier and M-900u power amplifier take solid state performance to another level. And...tone controls!

18, 42, 110, 142, 164

Playlists:

friends, colleagues, and readers let us know what they are listening to

20

OLD SCHOOL:

New contributor Michael Laurance discovers the joys of high resolution discs on a very reasonable budget

27

1095:

Jeff Dorgay explores CD playback with Rega's Apollo

37

The Audiophile Apartment:

Audiovector's compact Arrete monitors produce a big sound

44

JOURNEYMAN AUDIOPHILE:

MoFi Electronics has another winner with their latest turntable/cartridge combo

146

DEALERS THAT MEAN BUSINESS:

These are the people you should spend your hard earned money with

171

GET THE GEAR: Where to find our advertisers

what's inside:

35th ANNIVERSARY 002
1983-2018

Revisiting a classic.

As part of Sonus faber's 35th anniversary celebration last year, they produced 35 pairs of their legendary Stradivari speakers. Sonus faber has pair 001. We've got 002. Breathtaking.



FIGARO XL in Gray Olive
\$15,000 for standard finishes, \$16,500 as shown

"Excellent depth and rich tonal characterization of orchestral instruments"

Andrew Quint, The Absolute Sound RMAF 2018

"Unanticipated ability to reveal honest instrumental textures, realistic weight, significant impact, and accurate body."

Greg Weaver, Enjoy The Music.com RMAF 2018

"Its my take home speaker, I've never heard anything like this in this show..."

Peter Breuninger Terry Eringi, Avshowrooms, RMAF 2018



BELGIUM . CANADA . CROATIA . DENMARK . FINLAND . FRANCE . GERMANY . GREECE . HUNGARY . SOUTH KOREA . LUXEMBOURG . HOLLAND . SINGAPORE . SWEDEN . TAIWAN . USA . VIETNAM

AUTHORIZED DEALERS

HOUSTON, TX

3ma AUDIO
1431 W. Alabama St. HOUSTON, TX 77006
(832) 530 - 4716 sales@3maaudio.com

WAUPACA, WI

Sonare Coeli
1547 Foxfire Court WAUPACA, WI 54981
(715) 412 - 4139 nigel.b@prodigy.net

LAS VEGAS, NV

Argutus AUDIO
7650 Dean Martin Dr. STE. 101 LAS VEGAS, NV 89139
(702) 888 - 3787 info@argutusaudio.com

HIGHLAND PARK, IL

Toska AUDIO
186 & 188 Skokie Valley Road HIGHLAND PARK, IL 60035
(847) 926 - 3102 info@toskaaudio.com

USA DISTRIBUTOR

HIGH END By OZ LLC

11870 Santa Monica Boulevard 106672
LOS ANGELES, CA 90025
(424) 344 - 0011 oz@highendbyoz.com

M O O N
by SIMAUDIO

Your records
will never have
sounded so good.

110LP v2 - Phono preamplifier



simaudio.com



TONE

BRYSTON
28B³

More Power Scotty!

The Bryston 28B³ Monoblocks are the most powerful amplifiers we've ever used In-House.

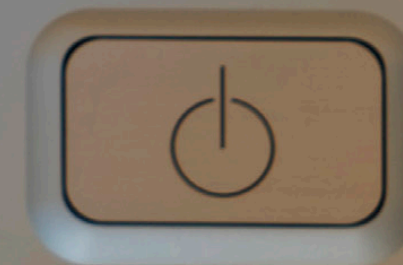



Paradigm

PERSONA®

**“FOR ALL THEIR VISUAL BEAUTY...
THE PERSONA SYSTEM DID THAT
MYSTIFYINGLY MAGICAL ACT—ONE
THAT ALL GREATEST SPEAKERS
ASPIRE TO—OF DISAPPEARING
COMPLETELY FROM PERCEPTION
AND LEAVING BEHIND ONLY THE
MUSIC OR MOVIE SOUNDTRACK.”**

Darryl Wilkinson, *Sound & Vision*



Persona 9H



Visit paradigm.com to find a dealer near you and schedule a demonstration of the new Persona.



no.96

PUBLISHERS LETTER

Summer is officially here in the Pacific Northwest, so it's a great time to invite friends over to enjoy some music, and maybe a meal or cocktails. Perhaps all three. Or trick them into helping you move big speakers in the house. But don't forget to feed them if you do! We're still rocking the (small and light) Totem Kin Play speakers – they've proven to work just about anywhere you'd like transportable sound of high quality. We've even taken them on a road trip. In a small Pelican case, they leave enough room in the trunk (or boot for the rest of you) of the convertible to pack an overnight bag.

Taking your music along, especially with a product that can stream digital music makes short road trips that much more enjoyable. Those more adventuresome can pack an HDMI cord to port movies from your laptop along with your favorite powered speakers. Who knows, the road trip might go longer than expected! One more streaming product we've really fallen in love with is the Bowers and Wilkins Formation Suite. We have a review of the stand mounted Duo speakers and Bass subwoofer. That the internal DAC will play or stream 24/96 files is an added bonus. For many, this is all the system you may need. And yes, you can add a turntable and expand to other rooms in the house. Read all about it in the Journeyman Audiophile column.

Shanon Swetlishnoff returns and will be doing a regular column "Shanon Says..." going forward. She is definitely one of the most passionate audiophiles we've had the pleasure to meet and being from the Great White North, super friendly too. I've never met a Canadian I didn't like. And she gets extra credit points for sharing my love of great classic rock.

Contributor Brian Gage is actually a graphic/web designer by day, and after some discussion, he's going to be taking over the design and assembly tasks at TONE for us, allowing me to concentrate on overseeing our continued expansion. This is a very welcome addition to the staff. Here's to you enjoying your summer. We've got quite a bit of material coming your way in the months to come, so we hope it will make for some good poolside reading.

Thank you for following along,

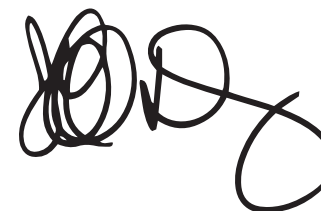

Playlist:

What Our Readers Are Into

Tone Playlists are sponsored by...

qobuz

Ramones—Rockaway Beach

Jonathan Richman—That Summer Feeling

Violent Femmes—Blister in the Sun

Sly & The Family Stone—Hot Fun in the Summertime

Frank Sinatra—Summer Wind

Blondie—In the Sun

Martha Reeves & The Vandellas—Dancing in the Streets

B52's—Rock Lobster

10cc—I'm Not in Love

Bee Gees—Stayin Alive



Emily Duff took a second from her usual column, recording a new album and the summer NYC heat to give us 11 of her favorite summer tracks. Because as she said, “I just couldn’t stop at 10.”



70 YEARS IN THE MAKING MC2152 70TH ANNIVERSARY VACUUM TUBE AMPLIFIER



A striking new design to celebrate our seven decades of handcrafting the best audio equipment the world has ever heard.

McIntosh[®]
LEGENDARY PERFORMANCE[®]
mcintoshlabs.com

Old School

Respecting HiFi's Past...

by Michael "Muppet" Laurance

Late to the Party—Pioneer Elite DV-45A \$42

People who know me will tell you one thing with certainty- I have a slight tendency to be late. Whether it be to the office, the meeting, the party, a family function, a dinner, or a gathering. Not grossly late, just a little tardy. Much to the surprise of my less technical friends, I'm similarly a late adopter of technology, often clinging to vintage gear and older formats (vinyl never went away in my house).

One of the formats that I walked into quite late was SACD, but once I did, I became ab-

solutely hooked. I bought my first player for a song, quickly acquiring a slightly better player, and then a reference-level player. Isn't that usually how our affliction progresses? However, I've always found my original bargain player to be extremely handy around the house and in other locations and thought I'd tell you about it here.

Let's start at the beginning, shall we? My whole addiction to this fantastic multi-channel world of music began with a Pioneer Elite DV-45A for sale locally for the ridiculously low price of just fifteen dollars, in nice condition, with the remote. Though I was skeptical, I had to jump on it - but it was fully functional, and in the state described.

I didn't even have any discs yet, but an audiophile friend (and frequent bad influence) had a sizable collection, lending me about a dozen to sample. He started me with some

Tellurium Q®

telluriumq.com info@telluriumq.com +44 (0)1458 251 997

10 products of the year and most wanted components

in just 2 years by preserving relative phase relationships in a signal



"If you're looking for a major jump in your system's performance, I'd suggest buying a pair of these instead of considering a hardware upgrade. Before you write this advice off to cable delusion, expectation bias, or the recent Mercury retrograde phase, please take note: I have never said this in TONE's 11-year history"

Jeff Dorgay, Tone Audio

"Well, I have just stumbled upon a speaker cable that I'm very tempted to put in a class of its own"

Mono & Stereo



"Tellurium Q have surpassed themselves here. It is often said that all cables colour the sound of a system to some extent, but the Silver Diamonds do it to a lesser extent than any other product I've heard so far."

John Myles, HiFi World



The effect of phase distortion can be likened to smearing a beautiful picture or looking at it through frosted glass. All signal cables do this to some degree and the better you tackle the engineering challenges to combat phase distortion the more natural the sound you get.



Old School

Respecting HiFi's Past...

by Michael "Muppet" Laurance

of the best offerings, both current and out-of-print, including Pink Floyd's Dark Side of the Moon and Wish You Were Here. My new habit was instantly formed. I can still remember my first experience hearing them on my own system. It was fascinating discovering a whole dimension that my multi-channel system now offered. Soon, I was shopping and beginning to build my own SACD collection. My new (used) Pioneer Elite was getting quite the workout.

The DV-45A is not precisely what I would call an economy unit, as the build quality is excellent and feature set robust. It plays both SACD and DVD Audio formats. It has the usual gloss black faceplate associated with Pioneer Elite gear, making it a beautiful piece. Slimmer than a lot of components, it slips easily into any rack. Connections are gold-plated and very solid. As a result, it's become a unit that I have taken with me to other locations. When a friend was doing a high-end headphone demonstration at his home, my humble player became our source component, using Miles Davis's Kind of Blue two-channel SACD as the demo disc. It performed beautifully. I was a little nervous that a room full of audiophiles would scoff at my contribution to this demonstration, but the DV-45A held its own. Which brings me to the final point - the sound. For their price point, which was modest, to begin with, these players are excellent performers. At the moment, I've gone back to that Miles Davis disc to evaluate a pair of speakers, and the DV-45A does everything that a good SACD player should. I've always been a fan of Pioneer DACs and the triple 192kHz/24-bit architecture presented here still feels good today. While many listeners claim that DVD-A is its strength, it performs equally well with all shiny discs.



I do have better SACD players in my home, but DV-45A gets an awful lot of use. I'm never afraid to use it as it sits now, in my two-channel system, putting a pair of speakers through their paces. (I have acquired a few great two-channel SACDs in addition to the Miles Davis disc.) It has a dependable accuracy and sound that lets me focus on the other gear I am evaluating. As audiophiles, we're always listening to our gear as much as we're listening to the music (or so we've been accused), but this player lets me relax and stop worrying about the source because I am familiar enough with it to forget about it.

Old School

Respecting HiFi's Past...

by Michael "Muppet" Laurance

This player was built before some modern video features became common, so should you plan on purchasing one, expect this to be more of an audio unit than a video machine. There is no HDMI output, but there is a component video output. Regarding video formats, this was considered a "universal" player in its time, playing DVD-video, DVD-R, and DVD-RW, but is not a Blu-Ray player. Again, video playback is hardly what I bought it for. I purchased this as an audio player, and I'm still presenting to you as a valid one, indeed. Purists can turn the video out from the front panel. If you are using it as a pure audio player, you will only need the video output to set all the menus up. The OCD in me says it should be off, but it doesn't make a marked difference in the sound quality. Also, the original remote is crucial to access all the setup menus. Don't buy a DV45A without it.

While some of the better Pioneer Elite SACD players are becoming tougher to find in the used market, the DV-45As are still plentiful, and can often be had for under \$40. This is an absolutely unapologetic way for someone arriving late to the SACD party. SACD titles are out there in the new and used catalogs and just about every place where discs can be bought. As long as you have the proper receiver or multi-channel preamp to support the format, it's a tremendously satisfying experience that I only wish I had discovered much sooner.



The Evolution of Perfection

PrimaLuna EVO

Four new ranges of tube integrations and separates, plus a new tube DAC

Separates available with transformer-coupled XLR

Every integrated is now a best-in-class tube headphone amp

Even larger custom toroidal power transformers

Becoming a tube expert is easy

Visit primaluna-usa.com or our YouTube channel



EVO 400 Preamplifier w/
transformer-coupled balanced in/out

Fantastico!



1095

Great sound for just over a G!

by Jeff Dorgay

The Rega Apollo CD player

\$1,095

Rega.co.uk

Publishers Note: We've labeled our entry level gear column "995" for almost ten years now, so in keeping pace inflation and tariffs, we're raising the price of entry to "1095" and letting the new Rega Apollo in the door. We will continue to scour the audio world for items below (and sometimes well below) this price point.

Everything seems to come around. With all the excitement for streaming building at a feverish pace, some people still like the old-fashioned way of serving up digital; namely, spinning a silver (or maybe gold) disc. World-renowned turntable manufacturer Rega was one of the last manufacturers to produce a CD player, but when they finally did put their engineering mettle to the task, their players were brilliant. And very analog sounding. Years later, nothing has changed, and their new \$1,095 Apollo is by far the most sonically engaging players we've heard at anywhere near this price. CD player? Have we gone mad in this world of curated playlists? Read on.

Taking up a tiny footprint only about 8 inches wide, 3 inches tall and 12 inches deep, the Apollo is meant to be a perfect bookend to Rega's remarkable Brio integrated amplifier, but it looks awfully nice on the Quadraspire rack with my Nagra Tube DAC. Patterned after the rest of the players in their lineup, the Apollo uses the same Starship Enterprise shaped lid for the transport. Rega's Roy Gandy is a brilliant man with a wacky sense of humor, so one never knows if this is on purpose or random. Either way, this manual lid assures that it is not another mechanism that will fail ten years later—Rega is always the master of simple elegance.



1095

Great sound for just over a G!

by Jeff Dorgay



Fit, finish, and functionality is always top of the class, and the Apollo feels much more expensive than its price suggests. As well as feeling rather heavy for its price. The front panel features a large display, flanked by a power button on the left and 4 buttons to control transport functions on the right. That's it. Perfect.

Quite the comeback.

1095

Great sound for just over a G!

by Jeff Dorgay

Several audiophiles that have ditched the compact disc in favor of streaming or vinyl have been sneaking back, with surprising results. On my recent podcast with John Darko of Darko Audio, he admits “I recently picked up a couple thousand CD’s at a great price recently. I like to start my day with a CD over the morning coffee.” Fascinating, captain.

Much as I love a well-oiled record player that’s set up to perfection, or a mile long Qobuz playlist, there is something pure about putting a disc in, pressing play, and hearing a full album from start to finish. “As the artist intended,” I believe the expression goes. Without having to get up and flip the record over. Not bad. Following Mr. Darko’s lead, I substitute the morning coffee for a dreadful bit of wheatgrass, and a copy of Brian Eno’s Thursday Afternoon. With absolutely no worries about network issues. Sixty-eight minutes fly by.

The Apollo comes out of the box with a sound that is tonally neutral, free of digital artifacts, and full of life. To get immediate perspective, the Apollo is put in comparison with a stack of Nagra Classic gear (amp, preamp, and DAC) driving a pair of Focal Stella Utopia Ems, with a dCS Bartok along for the ride in input two. The Apollo makes an excellent debut, and when switching back and forth between the much pricier competitors, the lines are quickly drawn.

Where was sound this good 30 years ago?

Had digital sounded this good, this natural 30 years ago, who knows how things might have shaken out in the music business? In the early 90s, big bucks digital was just starting to engage, but nearly everything for a thousand dollars sounded like rubbish. Harsh, brittle, and lacking in tone. I know, I was there.

Leave it to Rega, a company that’s always been a little bit behind on the trendy curve, (but over the top on the engineering curve) to build a player that’s this good for this price. Centered around the latest Wolfson WM8742 DAC chips and their own analog stage, all carefully implemented in a compact case. According to Rega’s Terry Bates, the player’s designer, the analog output stage is entirely different. (Again, you’d expect nothing less from Rega) He refers to it as “A discrete implementation of an op amp with a nod to forgotten about 1960s amplifier circuitry with class A output.” In short, Bateman calls the Apollo “greater than the sum of its parts,” and we concur.

Tracking through an original digital pressing of Peter Gabriel’s Security, (the fourth album to many of you) the dynamic range of this player is stunning, offering considerable weight and drive. The Apollo keeps the pace with the densely packed, thunderous drumming on the opening track, offering compelling low-level resolution during the quiet



Cardas Audio

Established 1987



The Nautilus Power Strip

- Cardas 4181US Outlets
- RFI/EMI Protection On Every Outlet
- Point-to-Point Wiring with Cardas 10 AWG Solid Core & 11.5 AWG Multi-Stranded Litz Conductors

www.cardas.com

1095

Great sound for just over a G!

by Jeff Dorgay



The transport option

Where many of today's digital enthusiasts add a modestly priced vinyl deck to their system to dip their toes in the pool of spinning black discs, the Apollo is a perfect choice for those going the other way. With so many CDs popping up at yard sales and in used CD stores, there's a lot available for next to nothing. And you don't have to worry about backing it up either.

beginning of "Lay Your Hands on Me." This is a ton of fun listening to a disc, long since ripped to NAS, that was one of the first CDs I purchased back in the 80s, with its massive "full digital recording" sticker on the cover.

The far reaches of the audio spectrum are equally well represented. The deep, growling bass at the beginning of Charlie Sexton's "Plain Bad Luck and Innocent Mistakes" puts the Focals to the task and rattles everything on the coffee table. Sorry, you can't stream Under the Wishing Tree on Tidal or Qobuz, so there are times when a player comes in handy.

Thanks to an optical and coax digital output on the back panel, the Apollo can be used as a transport for those with higher quality DACs, powered speakers, or an all in one product like the Linn Selekt DSM, or the Simaudio MOON 390.

Used as a transport with all of these proved excellent, but returning to the Nagra TubeDAC proved to be the best combination. The Apollo as transport feels right at home plugged into this \$20,000 DAC, and when playing 16/44 files, the sound from this combo often sounds more musical than what is streamed.

Sonus faber ELECTA AMATOR III Legacy refined



All In One Cartridge Setup Software & Test LPs

Anyone Can Be A Setup Guru

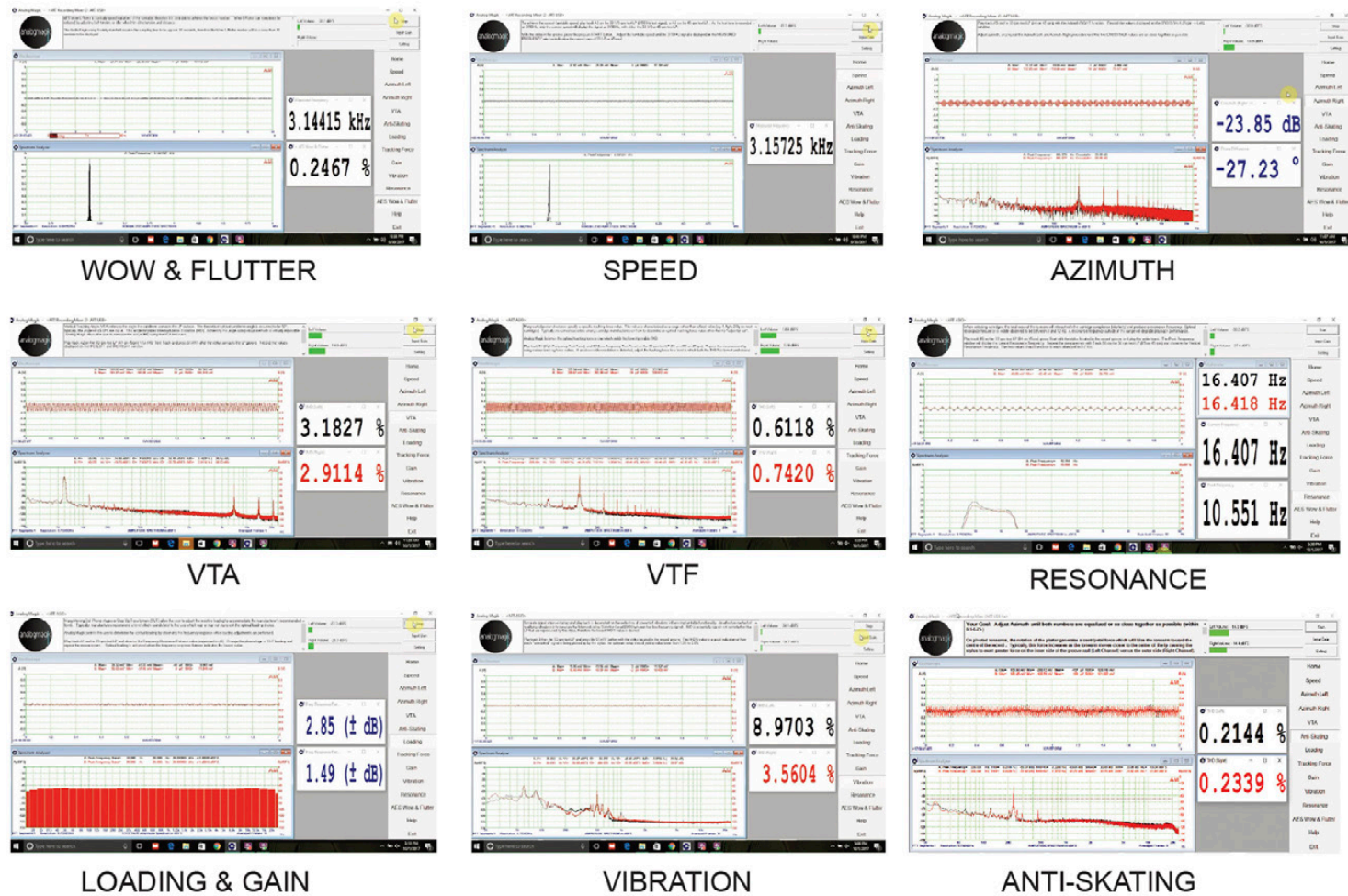

A perfect partner

Regardless of what you plug the Apollo into, the results are highly rewarding. In the context of a primary budget system, it holds its own and often betters the sound of turntables at the same price point. While our Rega P3/Exact combination still offers a bit more warmth and palpability through the midband, the Apollo corners the market on dynamics, and low bass punch. The two together make a formidable pair, offering the best of both worlds for a reasonable price - but that's always been the Rega ethos.

Yet plugged into a six-figure system, the Apollo doesn't disappoint in the least. Of course, it does not have the finesse you'd expect from a DAC or player that costs as much as a used Audi, but the basics are firmly in place, and that's what makes the difference between digital being engaging or not.

Whether you use an Apollo as a full function disc player, or merely a transport, it will serve you well. In addition to giving it one of our Exceptional Value Awards, we've purchased the Apollo for our permanent collection, and it will be receiving a Product of the Year award over at The Audiophile Apartment.

Can you feel the love?



The Audiophile Apartment

Sound for Small Spaces



The Audiovector SR 1 Avantgarde Arrete Speakers
\$5,500
audiovector.com

There is something special about speakers hailing from Denmark. I've always thought it was the quiet that gives Danish engineers the calm to come up with innovative ideas in speaker design. It goes without saying that we've never seen an unattractive Danish speaker, and the new Audiovector SR 1 Avantgard Arrete does not disappoint audibly or visually. The model we feature here is the top of four variations on the theme, starting with the \$2,295 SR 1 Super. The Super and Signature feature a soft dome tweeter and have about 5hz less bass extension (going down to only 45hz, where the Arrete model featured here has a claimed LF limit of 39hz)

Should you not want any electronics, you can order your Arretes as full active speakers with built in power amplifiers and streaming DAC. We definitely need to explore this option in a future review.

The people running Audiovector certainly get the cool guy award for building speakers that can be upgraded all the way from their base model to full active should you so desire.

Not only is this a very green solution to manufacturing, but it's a great way to build brand loyalty. Start where your budget allows and then merely upgrade later when you can. This is especially convenient with speakers, because so often this is the component you build your system around, perhaps even your whole room. Upgrade costs are very reasonable, so it makes more sense to "buy in" to Audiovector.

The Audiophile Apartment

Sound for Small Spaces



For a detailed explanation of these speakers and the tech behind them, please click here to be taken to the Audiovector website.

These beautiful speakers are available in two shades of white, gloss black and five different wood finishes. Our review pair arrive in American Cherry Piano (glossy) and are positively stunning. Stands are available at an extra charge from Audiovector, but for the duration of our review are placed on a set of 24" filled Sound Anchors stands. While functional, my trusty Sound Anchors stands are not attractive enough to do these speakers justice.

Sailing through the Bee Gees "Jive Talking" is a convincing first impression, proving that these small speakers have serious low-frequency output. Talk Talk's Laughing Stock shows off the airy nature of the SR 1 Arrete immediately pulling you into this misty, ethereal recording. Placing these tiny monitors nearly 12 feet apart with moderate toe in makes for a seamless musical presentation. Eyes closed, they sound like floorstanders.

Even in a 15 x 25-foot room, on the long wall, the Arretes fill the room, powered by a full stack of Nagra Classic electronics. (The Nagra Classic Preamplifier, Tube DAC and Classic Amp) If you are looking for a high performance, yet small footprint system, we couldn't suggest a better match than the Nagra gear. These modestly sized speakers play deceptively big, exhibiting a tremendous amount of linearity, producing inviting sonics at a low listening level. Turning the volume control down to the point where the Nagra modulometers barely move from their rest stops, the Arretes give a luscious rendition

Enjoy the Experience



PASS

Pass Laboratories
13395 New Airport Rd. Ste G., Auburn, CA 95602
(530) 878-5350 - www.passlabs.com

of Ella Fitzgerald, in a way few speakers can when playing at conversation level.

Speaking of specs, the Arretes have a published sensitivity of 87.5dB/1 watt, yet they are incredibly easy to drive with a 30 watt per channel tube amplifier, in this case, my PrimaLuna ProLogue ONE, with a fresh set of tubes from Upscale Audio's Kevin Deal. The Arretes high resolution and adaptable character now take on a warmer, more vintage sound via the EL34 tubes. Switching back to the 100 watts per channel via the Nagra, they become more forceful, more dynamic, and dig deeper in the LF region, yet both renditions are equally pleasant. The Arretes are indeed amplifier friendly.

Regardless of musical preference, the Arrete's offer up a vast soundstage, incredible dynamic contrast and a very refined top end, along with a perfect blend of woofer and tweeter. The level of coherence they offer is the closest you can get to an ESL or single driver speaker without choosing that option.

We might say "Not bad for a \$15k pair of speakers," but the Arretes are only one-third of that price. Combine the useful form factor, and these add up to be the best performing small monitors we've heard in a long time.

At first glance, you might think this is another two-way monitor with a ribbon tweeter, but this is an air motion transformer up top. The subtle difference is the AMTs radiation from the rear of the driver, which in the Arrete, is channeled out through the back of the speaker enclosure. The result is a much larger spatial presentation than a mere front-firing ribbon can accomplish.

This rear firing energy makes these speakers very easy to set up, and whether you have a large or small room, they are easy to get in

the room and "tuned" in short order. Trying diffusion behind the speakers kills the airiness, so I suggest minimal if any room tuning with the Arretes. A solid hour maximizing speaker position should be all you need, which again makes these speakers very environment-friendly. Even if you have to throw them in the room, without regard to precise placement, they will deliver an excellent performance, though a little bit of ultimate imaging will suffer. You can't have everything. At least not yet.

Tasty as these speakers are at low volume, they can be played very loud without distortion. They generate some pretty dangerous sound pressure levels, and the limitation will be the lowest bass notes you are trying to capture. Even when playing a long list of TO-SCA tracks, I was amazed by how much bass these small monitors could produce before the woofer cones began to hint that they were at the limit. You'll bottom the woofers long before you run the tweeter into clipping.

Audio Vector tells us that their Arrete models "are to Audiovector what AMG is to Mercedes, RS is to Audi and M is to BMW." That had me hooked, and as I unpacked these tiny yet potent monitors, the level of care in their construction is easy to see. They are simply beautiful to behold. A fellow colleague of mine and I were discussing that weren't that many speakers at this price that are truly exciting. Granted, there are several very nice, musically satisfying speakers for \$5k a pair.

But you don't buy an AMG, M or RS because they are nice. You buy them because they are exciting. And the Audio Vector SR 1 Avant-garde Arretes are exciting.

We would like to give a special thanks to Antonio Long of AudioVision San Francisco for helping to facilitate this review. 🎵

Audio Vector tells us that their Arrete models "are to Audiovector what AMG is to Mercedes, RS is to Audi and M is to BMW."

That had me hooked...

Playlist: What Our Readers Are Into

Tone Playlists are sponsored by...



David Bowie—Rebel, Rebel

Tim Curry—Summer in the City

Bryan Ferry—Boys and Girls

Lenny Kravitz—Are You Gonna Go My Way?

Van Halen—Beautiful Girls

AC/DC—C.O.D.

Cheap Trick—Hello There

The Tubes—Theme Park

Strawberry Alarm Clock—Incense and Peppermints

Gino Vanelli—Black Cars

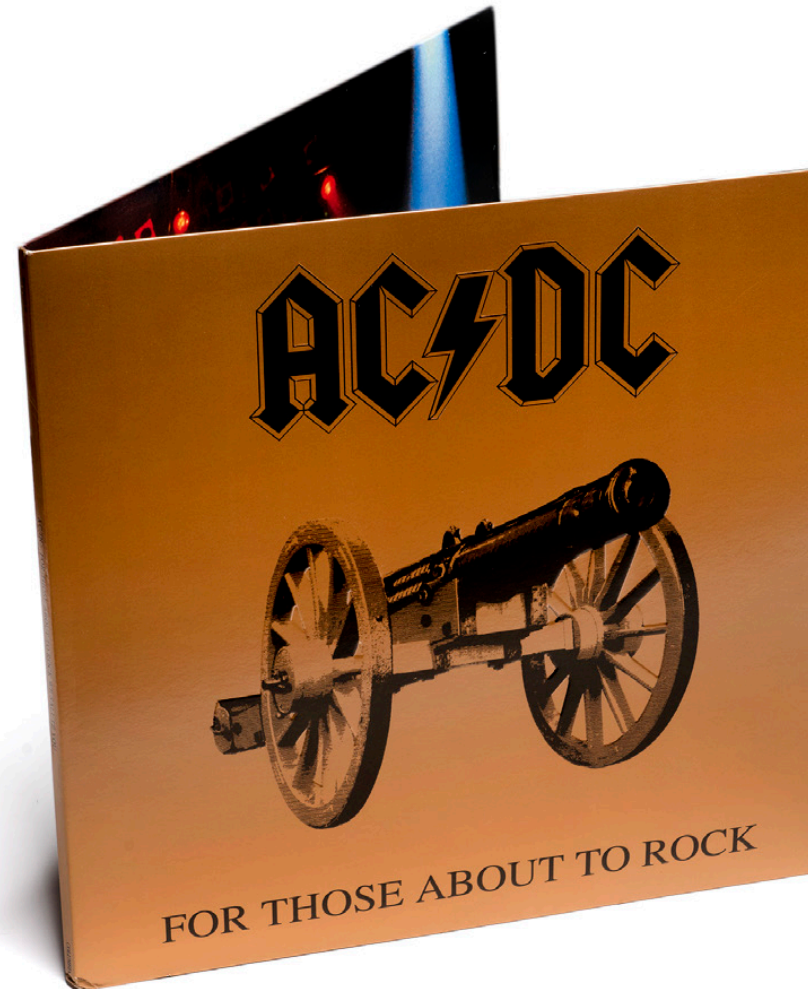

Inspired by Emily Duff, our publisher has been rethinking his favorite summer tunes, preferably enjoyed with the top down.



THE BEST OF BOTH WORLDS: THIN FILM ACCURACY, DEEP BASS THRILLS.

Cone speakers can't reproduce mid-range and high frequency audio with the lifelike detail and three dimensional effect of an electrostatic loudspeaker. Nothing delivers bass like woofers in a box.

MartinLogan combines these elements in the most advanced electrostatic hybrid loudspeaker ever, **Renaissance ESL 15A**, flagship of the Masterpiece collection.

With a unique suite of innovative tech and proprietary design elements, these loudspeakers deliver detailed imaging and dynamic soundstage, even in the most challenging listening spaces.

No other loudspeaker features the controlled dispersion radiation pattern of a curvilinear electrostatic transducer combined with our reflection-defeating PoweredForce Forward woofer alignment. The result is breathtakingly accurate and seamlessly integrated full-range performance. On-board Anthem Room Correction (ARC®) technology instantly optimizes response for the best sound in any room.

Renaissance ESL 15A is a revolutionary melding of form and function. This is exactly what we mean by *Truth in Sound*.

The reviews are in. This is our Masterpiece

martinlogan.com/truth

"Yes, I've drunk the Kool-Aid for years. But even though I'm pre-primed to like electrostatic-panel speakers, I'd never found a one-stop solution I could live with. Now that a MartinLogan active subwoofer endowed with ARC-2 has been successfully mated to an XStat panel, anyone serious about big, full, accurate sound reproduction can start here. Unconditionally recommended."

*Renaissance ESL 15A
Jon Iverson, Stereophile*

"...the best bass response I've ever heard in my room in the areas of overall smoothness of response and of clarity, definition, and pitch differentiation."

*Impression ESL 11A
Paul Seydor, The Absolute Sound*

"It's a powerful, dynamic, musical fun maker with the usual MartinLogan characteristics of good imagery and great detail... and terrific integration between cones and panel. Factor in the benefit of subtle DSP room compensation and this electrostatic hybrid design comes extremely highly recommended!"

*Impression ESL 11A
Alan Sircom, Hi-Fi+*

"MartinLogan has hit a home run... This speaker improves upon the traditional MartinLogan strong points of transparency and detail and adds a much improved bass section to create a well-rounded, great-sounding speaker."

*Expression ESL 13A
Brian Kahn, HomeTheaterReview.com*

"...a world-class speaker. It is revealing, accurate and has the huge soundstage one expects of a dipole radiator."

*Impression ESL 11A
Glenn Young, Secrets of Home Theater & High Fidelity*

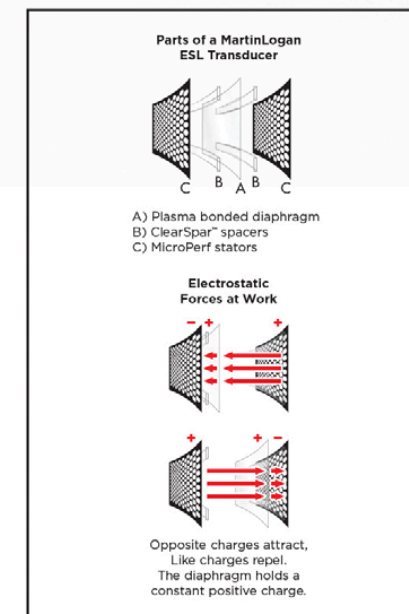

Renaissance
ESL 15A
by **MARTINLOGAN**

35
YEARS
1983 - 2018

The Journeyman Audiophile

Sound for for a bit more than a G...

The MoFi StudioDeck+U Turntable (with UltraTracker MM Cartridge)

\$1,499

mofielectronics.com

After going through the ten-minute assembly procedure, how could I not play some Skynyrd? Especially when it's on MoFi as one of their Master Recordings? Sailing all the way through Street Survivors proves a ton of fun, giving pause to how competitive this segment of the turntable market has become. No doubt because of how much better equally priced DACs are these days, and how many outstanding players have entered this arena, concentrating on this price point.

Much as I like the level of sheer sound quality MoFi's StudioDeck+U offers, like the other tables in their range, the SD+U allows you the option to take it further as your involvement with analog increases. A removable power cord, removable tonearm to preamp cable and of course, the cartridge can all be swapped out later, revealing even more performance. In the world of analog, every detail matters, and it's nice that once you get used to your SD+U and ache for more performance as your record collection grows, it's a piece of cake. Not that you need it, but I really enjoy using the SD+U with MoFi's own record weight. It works great, fitting right in with the aesthetic of the table. Please click [here](#) for the full list of specs for the SD+U.

Quick unboxing

Setup is straightforward and quick. MoFi has done an incredible job of packaging and labeling everything, so even someone that has never set up a turntable will have their SD+U playing records in no time at all. The attention paid to all the packaging details almost feels Japanese in execution. The belt and a few sundry items are all individually wrapped; even the anti-skate weight and an additional set of cartridge mounting screws (with a screwdriver) come packed in small cardboard tubes. There's serious pride of ownership going on here.

The cartridge comes pre-aligned, so you only need to remove the stylus guard, install the counterweight (and twist it to its marked position) and thread the anti-skate counterweight. I suggest unless you have thin fingers like Yoda, to have tweezers on hand. That is the only thing not supplied by MoFi.

Checking the alignment with the Analog Magic alignment system, showed the UltraTracker MM cartridge to be well setup from the factory. A digital scale reveals that the factory preset puts tracking squarely in the middle of the 1.8 - 2.2-gram range. The UltraTracker MM gives

The Journeyman Audiophile

Sound for for a bit more than a G...



its best results slightly heavier at 2.15, but again, we are picking nits. Follow the directions and dig it. Analog Magik also reveals excellent speed stability, something you don't always get at this price point.

Finally, one very important detail addressed with the SD+U is that it does not make even the slightest sound, should you turn it off with the system on. We've used a number of \$5,000, even \$10,000 turntables that send a massive turnoff transient through the speakers should you shut it off with the rest of the system running. A very thoughtful touch, that just might save a tweeter or two.

World class feel

Built here in the US, with guidance from Allan Perkins, the man behind the incredible Spiral Groove table and managed by John Schaffer, the man behind Wadia, the finished product looks, feels and sounds more expensive than the \$1,499 price suggests. Everything from the 10-inch tonearm to the Delrin platter will tick all the boxes for quality minded audiophiles.

MoFi has not revealed who makes their UltraTracker cartridges, but again, this is a winner. Nearly all of the \$500 cartridges we've auditioned are usually good trackers, but lacking either tonally or dynamically. This cartridge gives you all three, offering a high end that is smooth, refined and extended - again something not expected for this price. Their \$800 MasterTracker cartridge (preinstalled in their top table we reviewed last year) was also at the top of its class, but getting so much of that flavor for \$500 is over the top good. This table and cartridge combination is sure to excite vinyl lovers new and old. Budget minded audiophiles will love saving \$200 buying the two as a bundle.

Because playing records is such a tactile experience to begin with, the style and design cues that surround the SD+U makes it as much fun to actually use as it is to listen to. The low key, minimal footprint design will be at home on any rack and in any environment.

Supreme sound

This is no poser turntable, though. When the stylus hits the groove (gently, thanks to a well-implemented cueing mechanism), the music flows with ease. This cartridge is really grain free - and as its name



Diana[®]

The Journeyman Audiophile

Sound for a bit more than a G...

suggests, an excellent tracker. The blazing guitars in Matthew Sweet's *Altered Beast* (via the Intervention Records remaster) cut through the dense mix with ease, keeping Sweet's vocals locked in place amidst a cluttered soundfield.

As mentioned earlier, the top end of this cartridge is incredibly sweet and moving the clock all the way back to 1983 with Liz Story's *Solid Colors on Windham Hill*, reveals delicate piano playing with plenty of texture and decay, with solid attack as well. Overall, this is just a great little cartridge that makes no missteps.

your record collection. Should you be starting your analog journey here, you'll get spoiled in a hurry. This one's a keeper.



While the SD+U offers robust, tuneful bass response, it doesn't offer up any feedback, even placed on a modest Quadraspire rack, set on a hardwood floor. The mechanical precision of the SD+U makes for an incredibly quiet presentation. Using the MoFi combination with our reference VAC 170i integrated (with built-in MM and MC phono) and the Focal Stella Utopia EM speakers reveals a dark background from music to emerge.

Wrap it up

MoFi has made it so easy for you to start spinning records, how can you resist? For those of you stepping up from an entry-level/budget table in the \$300 - \$500 range, you'll be amazed at just how much music is lurking in



BRILLIANT & GORGEOUS
FALL IN LOVE WITH YOUR VINYL AGAIN



HANA M SERIES MICROLINE



HANA S SERIES SHIBATA

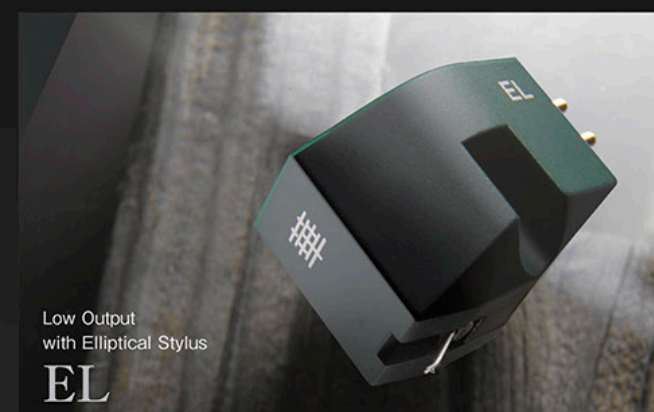

HANA E SERIES ELLIPTICAL

 **HANA**
BY EXCEL SOUND
HANDMADE IN JAPAN

MUSICAL SURROUNDINGS

www.musicalsurrroundings.com | 510.547.5006

Shannon Says...

Audio Musings from up North

by Shanon Swetlishnoff

GOLD NOTE
PSU-10

A Golden Experience with Gold Note PH10 and PSU10
\$3,000
goldnote.it

The Gold Note PH10/PSU10's swept back cooling fins inside the gorgeous brushed silver finish instantly catches my eye, but the superb sound is what makes this analog enthusiast swipe the credit card. As the PH10 has already been covered here at TONE, my mission is to tell you about the difference the PSU10 makes to this outstanding solid-state phono preamplifier. And it is a significant difference.

The Italian manufacturer Gold Note is well known for producing a full range of audio components, some of which we have reviewed in these pages to great result. The PH10 phono is packed with options and features, offering 6 equalization curves including the RIAA, Deca-London, and American-Columbia curves. Gold Note takes this a step further, by allowing you to customize the curves to your listening pleasure, allowing that last bit of fine-tuning, and the best possible vinyl experience. Got some great reggae discs you picked up on that vacation to Jamaica that never sounded quite right? Now you're covered.

The PH10 offers two phono inputs, each able to be set for MM or MC cartridges, with four different gain levels available: 3dB, 0dB, +3dB, and +6dB. This translates to a gain range of 62dB to 71dB, so it will work efficiently with lower output MC cartridges in the .25-.3mv range. The PH10 also has 9 different loading options from 10 Ω to 47 K Ω , making it the most ver-

Shannon Says...

Audio Musings from up North

by Shanon Swetlishnoff



satile and adjustable phonostage in its class.

Adding the PSU10 power supply doubles the price of the original PH10, now tipping the scale at \$3,000, yet it is still a significant value proposition, perhaps even more. The increase in transparency, resolution, and separation put it into a different league entirely. Now judging it as a \$3,000 phonostage, it is still a killer deal. Instead of relying on massive capacitor banks to filter the AC, Gold Note takes a dual choke approach.

Quick setup

Thanks to the small footprint of the PSU10, which is identical to the PH10, the pair will take up no more space than a standard, rack mount component. Setup is straight forward, utilizing an umbilical cord between them. If you are adding the PSU 10 to your existing PH10, be sure that both units are powered down and unplugged before connecting the two together. Then, power up the PSU 10 first, from the rear panel, then the PH10 and use the PH10s front panel switch as a master. Most importantly, you will need to update the firmware on your PH10 first, so that it will recognize the external power supply. Stop

here to get the update: www.goldnote.it/ download Internal component layout in both the PH10 and PSU10 dictates placing the power supply to the left of the phonostage, instead of on top or to the right. I suggest, maximizing the space between them if your rack allows, to achieve minimum background/electrical noise.

Listening

The PSUs effect is heard instantly, this is not an upgrade that you have to strain to hear. Using the Acoustic Solid Vintage Exclusive turntable, fitted with the Ortofon Quintet Red MC cartridge, (with PH10 set to 6db/470 ohms and enhanced RIAA curve) a bevy of test tracks from Tragically Hip, AC/DC and Doris Day (how's that for non-audiophile selections?) all aspects of the PH10's are substantially improved. Tracking through Doris Day's rendition of "When I Fall in Love" her voice is more prominent, smoother and more lifelike with the power supply installed. Paul Langlois' signature guitar in "Wheat Kings" is a long term reference for textural ability, and the PSU10 magnifies this texture, becoming even more lifelike, due to the additional dynamic swing that comes with higher power

You already own the music.
You might as well hear all of it.

Contact The Sound Organisation
today for your closest retailer.



rega

ProAc
perfectly natural

Quadraspire

THE
CHORD
COMPANY

BRYSTON

hii
Face the Music

support@soundorg.com
(972) 234-0182
soundorg.com

The
sund
Organisation



reserve. Ditto for the drumming in AC/DC's "Let There Be Rock." Lead singer Bon Scott's signature growl is even more in your face. Awesome.

Finally, resolution of the most delicate musical details puts this purchase over the edge and is most evident with acoustic and vocal pieces. It's almost easier to hear when removing the PSU10 - the natural rendition of the human voice fades into the background more, and it won't take you long to become addicted. I noticed the increased performance even easier to notice with headphones on. The increased musicality offered by the PSU10 went that much further to make my headphones disappear on my head.

Though I purchased both at the same time, I see where the love comes from for the original PH10, but I couldn't live without the power supply. If your budget affords you the luxury, get both if you can! Bravo to Gold Note

for making this a two box solution though, because it does give you a chance to grow as your system improves. The bigger your record collection, the more this purchase justifies itself. Adding the PSU10 to your PH10 will invite some extended listening sessions.

Highly recommended.



50 BRANDS
8 DEMO ROOMS
1 LOCATION

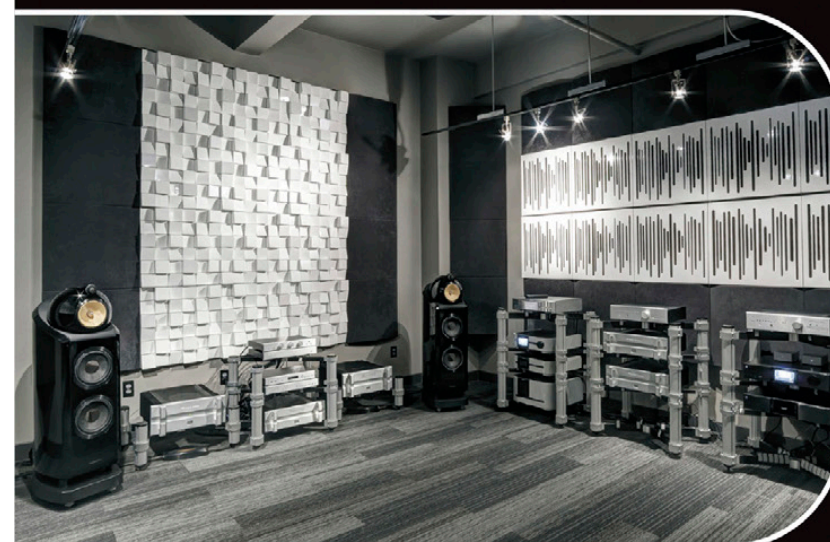



Easy Peasy Lemon Squeezy



Control your entire audio environment with whatever's handy.

It all makes sense when you hear **Linn DSM**.

Find out more at www.linn.co.uk



In House

The soundtrack of assembling the issue...

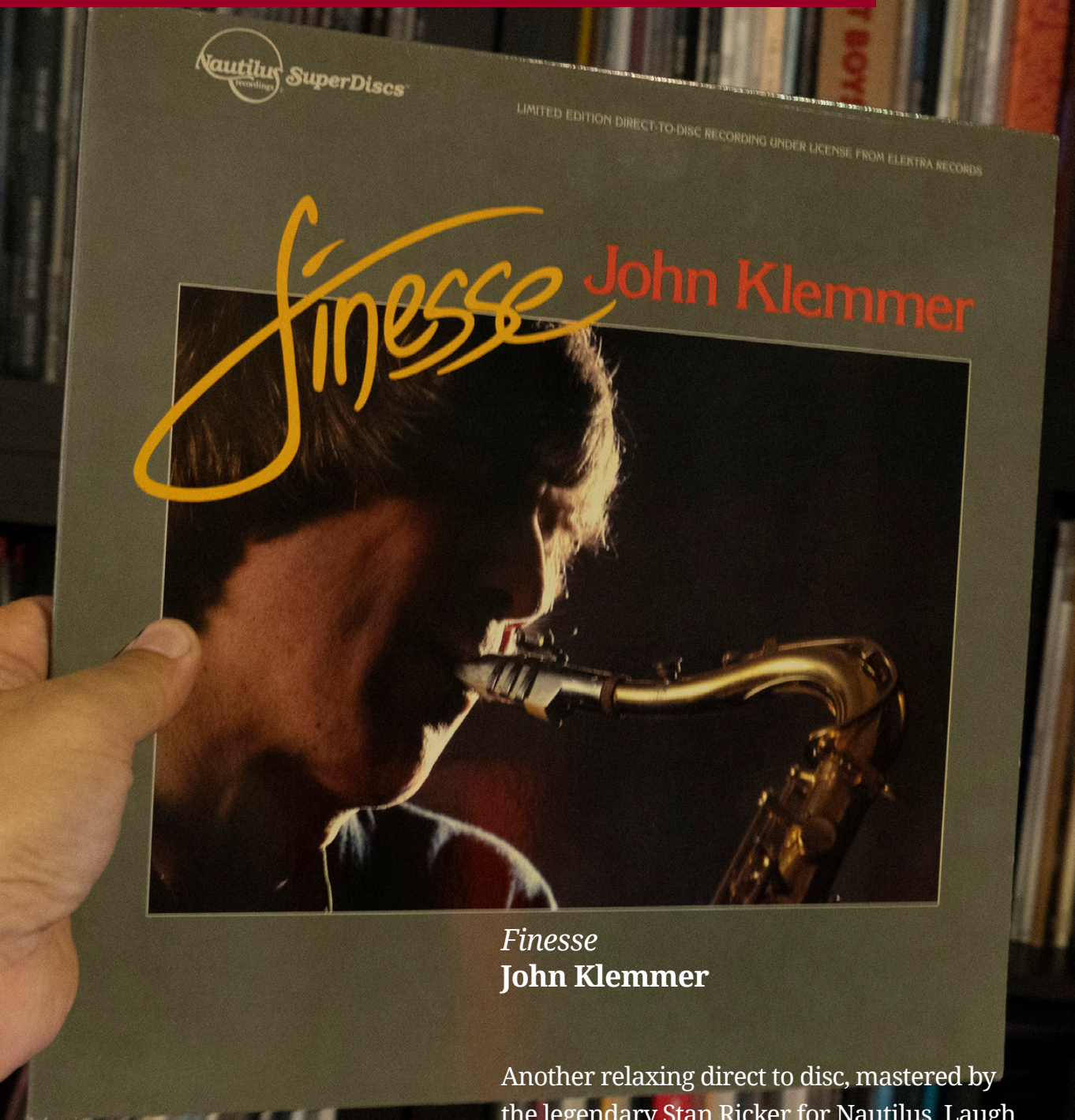

Finesse
John Klemmer

Another relaxing direct to disc, mastered by the legendary Stan Ricker for Nautilus. Laugh if you want, but that sax on the opening track, is one of the biggest, most dynamic sax sounds you will ever hear. Shake the moth balls off that leisure suit, while you're at it!



European Audio Team's C-Major

Exceptionally engaging, endearing sound.*

"It looks stunning...
Best of all it sounds fantastic."

Highly recommended.

Exceptional Value Award Winner

Jeff Dorgay
Tone Audio

"...screams sophistication,
obviously a luxury product...
a winner and a wonderful
component. Combine such
elegance with high-tech
materials and exemplary
finishing -- as EAT has in
the C-Major -- and you've
got a winner."

Highly recommended.

*Jason Thorpe
SoundStage Hi-Fi!

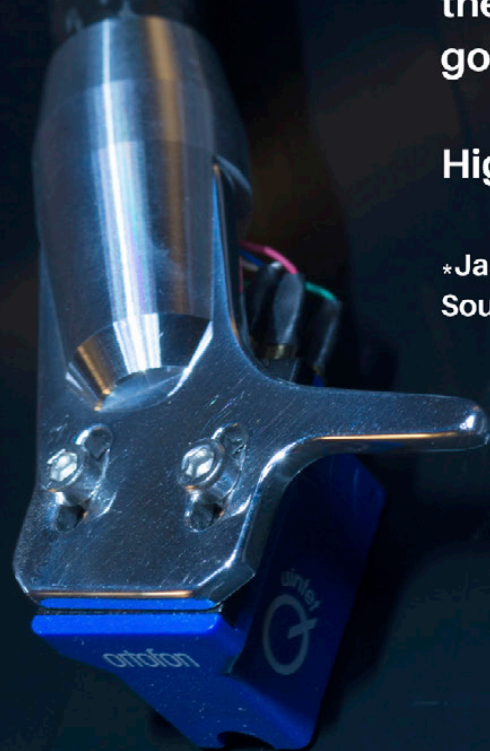

VANA is proud to represent EAT in the USA vanaltd.com

MINE: it should be yours

Welcome to MINE:

We're not just crazy about music and hi-fi here at TONE. While we can put many labels on our ethos, claiming to be music lovers, audiophiles, or perhaps even qualityphiles, that doesn't even cover it. Having me so many of our readers from all over the globe, as we are well into our 13th year, I'd say our readers are playful and inquisitive to say the least.

You've told us you like automobiles, motorcycles, fine art, bicycles, toys, cameras... Well, you get the picture. Lumping this all under a banner labeled "Style" seems too limiting. Let's face it, we're all a little selfish when it comes to our stuff. So, let's call it what it is - MINE! And we'll be sharing more of our favorite stuff as we go.

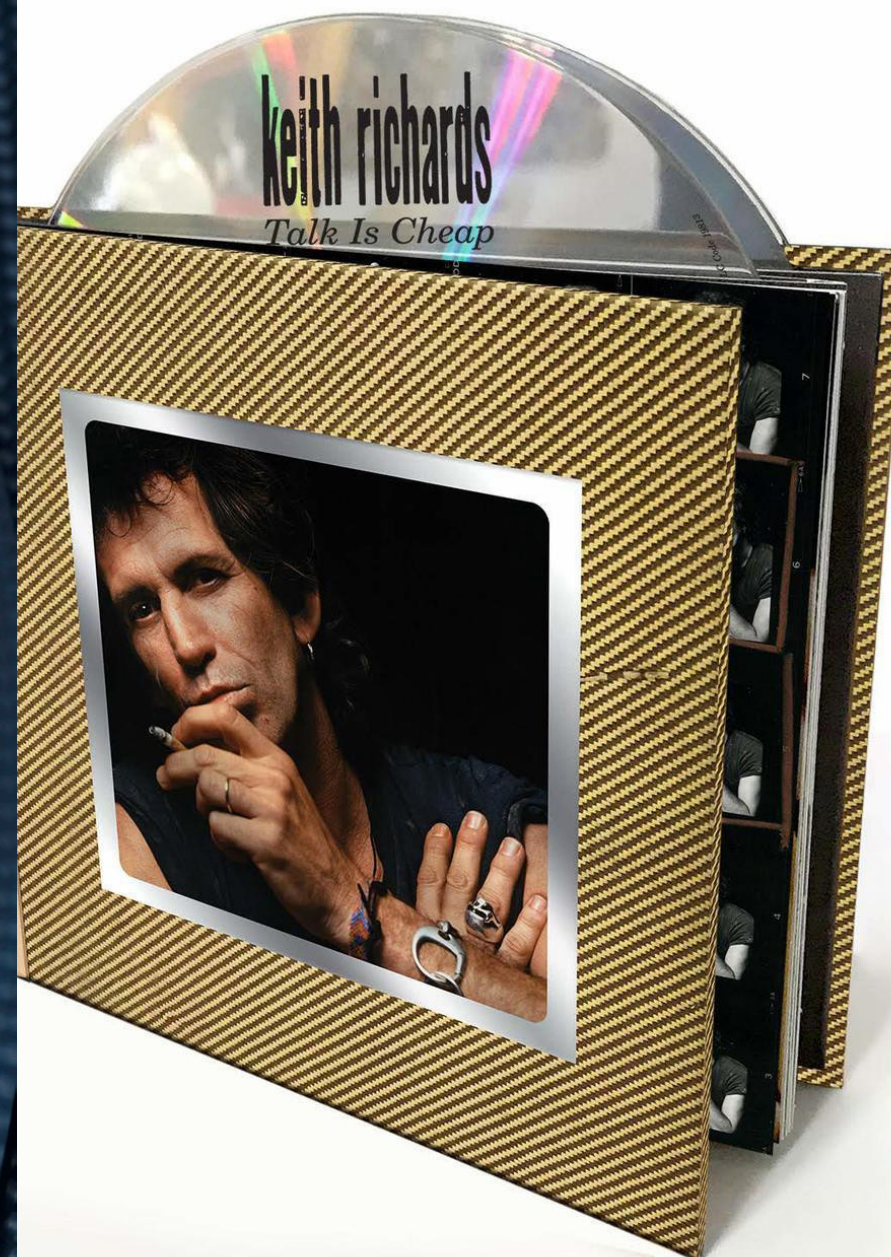

**Keith Richards 30th Anniversary
Talk is Cheap Box**
\$79-\$599
elusivedisc.com

How much Keith do you want? The entry level, 2CD set you see here is not crazy money, but the big, big, box of Keith, made by the Fender custom shop of the same wood his Telecaster is, will set you back serious coin. Whichever road you choose, this looks like fun.

audio research

HIGH DEFINITION®

REFERENCE 160 M VACUUM TUBE POWER AMPLIFIER



SOUND HAS NEVER BEEN SO TRANSPARENT

After two years in development, the all new REF160M is now shipping. It features switchable Ultralinear/Triode operation, proprietary auto-bias, output tube monitoring and protection, an innovative transparent power meter, and legendary Audio Research sound.

Contact your local Audio Research Dealer for an audition.

audioresearch.com

MINE: it should be yours

Vintage TEAC Reel to Reel Deck

\$299 - \$399

gigharboraudio.com

Our friends at Gig Harbor Audio are always finding great reel to reel tape decks, and like puppies, they bring them back to the shop, clean them up, and find them a new owner. Think of them as “tape deck rescue.”

You could get mental about the current tape craze and spend crazy money on a deck, or you could go to GHA and just have a little fun. Make a few great mixtapes and enjoy.



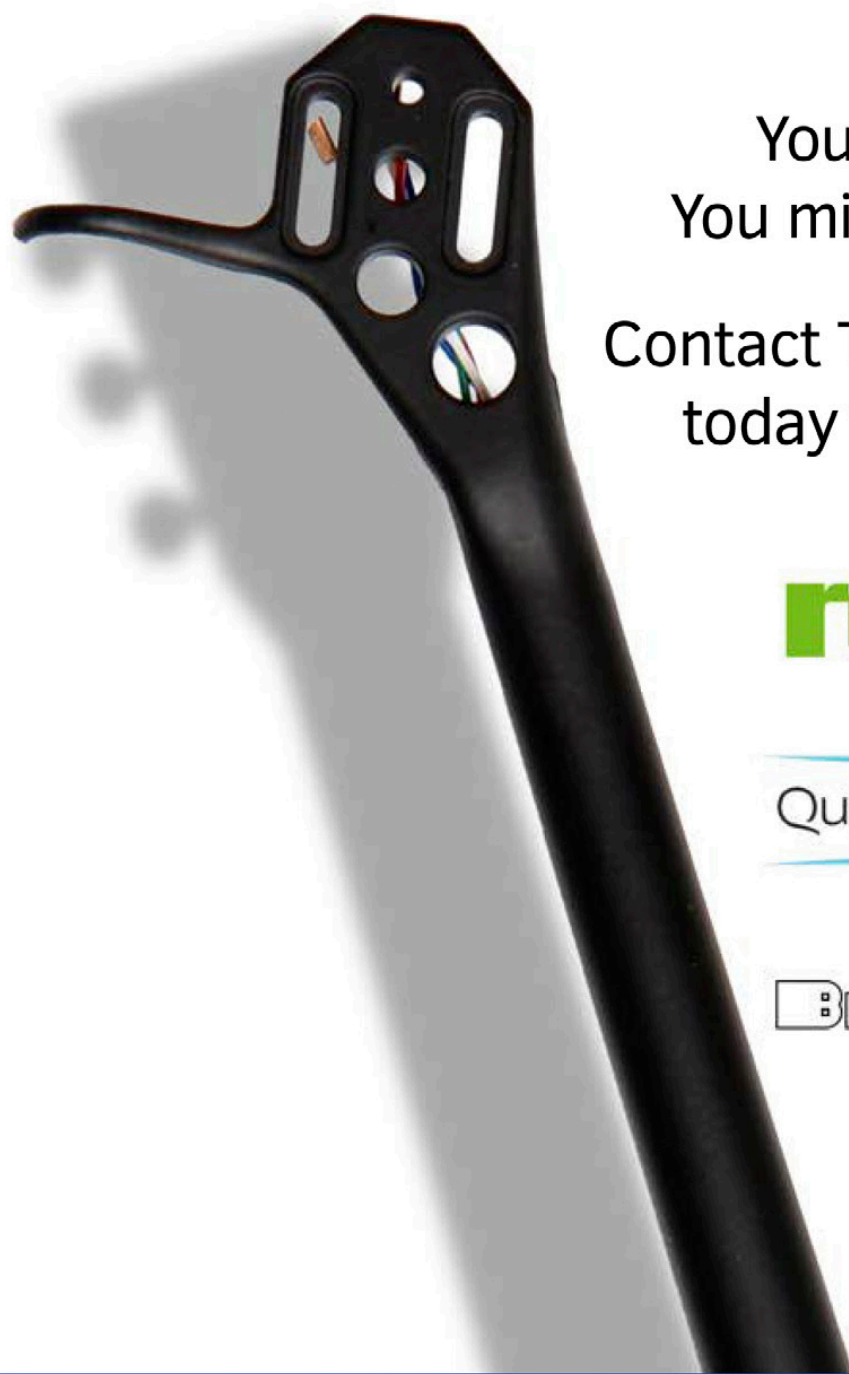

You already own the music.
You might as well hear all of it.

Contact The Sound Organisation
today for your closest retailer.



MINE: it should be yours

Smurf PEZ
\$3
amazon.com

What could be a better combination than
PEZ candy and Smurfs?

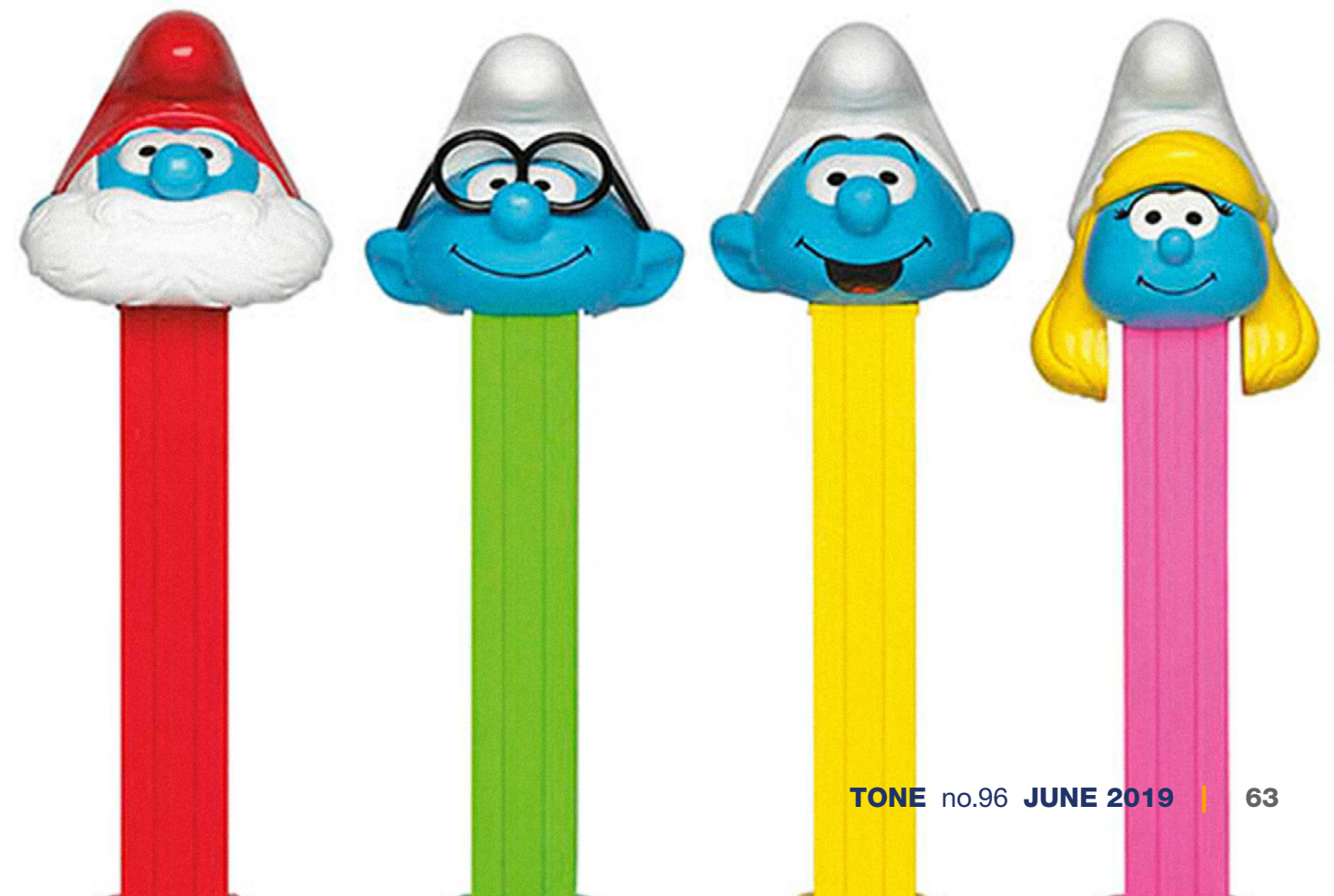

support@soundorg.com
(972) 234-0182
soundorg.com



MINE: it should be yours

Brixton Forged PF10+ 2-Piece, Carbon fiber wheels

starting at \$16,000/set

brixtonforged.com

At the upper end of the scale, wheels can be almost as expensive as premium cables or phono cartridges. The Carbon+ range of wheels from Brixton Forged use a full carbon fiber barrel, with APP 6061-T6 aluminum centers. Brixton claims a 25% weight savings over forged aluminum.

Valet parking mistakes will be costly with these.



Boulder
The Foundation of Your System



— EXPERIENCE THE NEW —
1110 PREAMPLIFIER & 1160 STEREO AMPLIFIER

Bellissimo!



Strumento n° 4

AUDIOLUX
FLIGHT

Audiolux proudly represents Audia Flight in the U.S.A | audioluxllc.com

MINE: it should be yours

Cryo Stash IPA

\$10/6-pack

hopvalleybrewing.com

Well, we cryo tubes, wire, and all things audio, so “cryo-treated” beer seemed very intriguing at the local liquor store. And, without prompting, the local beer merchant went on at length to tell me about the “benefits of cryo-treating...” Sound familiar? Beer Advocate rates this one 3.86 “Very Good,” and we concur.



MINE: it should be yours

Elevation Lab Anchor

\$11.95 (pro version \$15.95)
amazon.com

It seems like your headphones are always in danger of something when sitting on your desk-top. Elevation Labs has a two-phone solution with their under desk hangers. Those of you with larger, heavier phones, can use the Pro version. Either choice is a great way to avoid desk clutter.



Best Integrated Amplifier on the planet.. Period!



AUTHORIZED DEALERS

HOUSTON, TX

3mA AUDIO
1431 W. Alabama St. HOUSTON, TX 77006
(832) 530 - 4716 sales@3maudio.com

SAN CLEMENTE, CA

Cake Audio
http://cakeaudio.com
(949) 369 - 9262 ken@cakeaudio.com

LAS VEGAS, NV

Argutus AUDIO
7650 Dean Martin Dr. STE. 101 LAS VEGAS, NV 89139
(702) 888 - 3787 info@argutusaudio.com

NORTH AMERICAN DISTRIBUTOR

HIGH END By OZ LLC

11870 Santa Monica Boulevard 106672
LOS ANGELES, CA 90025
(424) 344 - 0011 oz@highendbyoz.com

DEALER INQUIRIES WELCOME



Apple XDR 32" Monitor
\$4999 (Pro stand, addl. \$999)
apple.com

Whether you're relieved or outraged over the stand being an additional G you must add to the cost, or a G you don't have to pay for because you already have one, it looks like Apple has again raised the bar for desktop imaging. Considering what a game changer the original 32" Cinema Monitors were, this will probably be the same. Except, this time we'll wait for the first round of change and buy it when they drop the price to \$2,999.

MINE: it should be yours



MINE: it should be yours



Kodachrome
No Longer Available
kodak.com

And even if you do find some in the freezer, there's nowhere left on Earth to process it. There is one fellow that has figured out an "alternative process," but he's claiming no image stability (long the trademark of this iconic film) and the "greens of summer" are no longer available. At least not in the literal sense.

But what kind of a magazine that loves all things analog would we be, if we didn't at least lament?

AUDOLICI From Portugal



A25M Integrated Amplifier



I50 "Swing"
Integrated Amplifier



AVP-01 PreAmplifier



harold@soundconsultant.com
608 208 3536 USA Distribution
www.soundconsultant.com



MEDITERRANEO

THE ITALIAN TURNTABLE

Our journey started 25 years ago by designing our very first turntable driven by our love for analogue music and a real passion for vinyl.

Such passion defines all our creations and particularly turntables, stimulating us to design with great care and attention every single detail in order to realise the most fascinating sources of music.

Mediterraneo is the pinnacle of Gold Note: a creation that redefines the traditional design of the turntable through innovative shapes, technical solutions and quality materials in order to merge tradition and technology and achieve the best musical experience.

Mediterraneo combines the greatest attention to technical perfection with pure beauty.

Manufactured by our local craftsmen, the Mediterraneo is fully hand-made: designed with a 60mm curved plinth made of aged Italian Walnut chosen for its exceptional elasticity, strength and high-density, then coupled with a 20mm board made of polished acrylic and finally reinforced with a 3mm stainless steel board for extra rigidity.

Every detail of Mediterraneo enhances its musicality: a refined technical innovation achieved through elegant and smooth lines.



MINE: it should be yours

Multiperson Float

\$369

funboy.com

How could you NOT expect a company named Funboy to make something like this? Next time you're in the mood to eliminate a few friends from your island, round up a few friends with the lure of drinks and snacks. Float out from shore just enough to make it a healthy swim back. Start a cable discussion and throw the people you don't like off the float.



MINE: it should be yours

Iso Acoustics GAIA 1 Feet
\$599/four-pack
isoacoustics.com

We've been experimenting with the GAIA 1s in a number of different areas; beneath speakers, under heavy power amplifiers, and the results have been fantastic. In every case, they have added to the clarity of the musical presentation.

Iso Acoustics has other solutions, and makes the GAIA footers in two smaller sizes, all weight dependent.

If you have lighter components or speakers, you may only need the IIs or IIIs – saving money in the process. Anyone wanting to get maximum performance from their system should investigate a set.

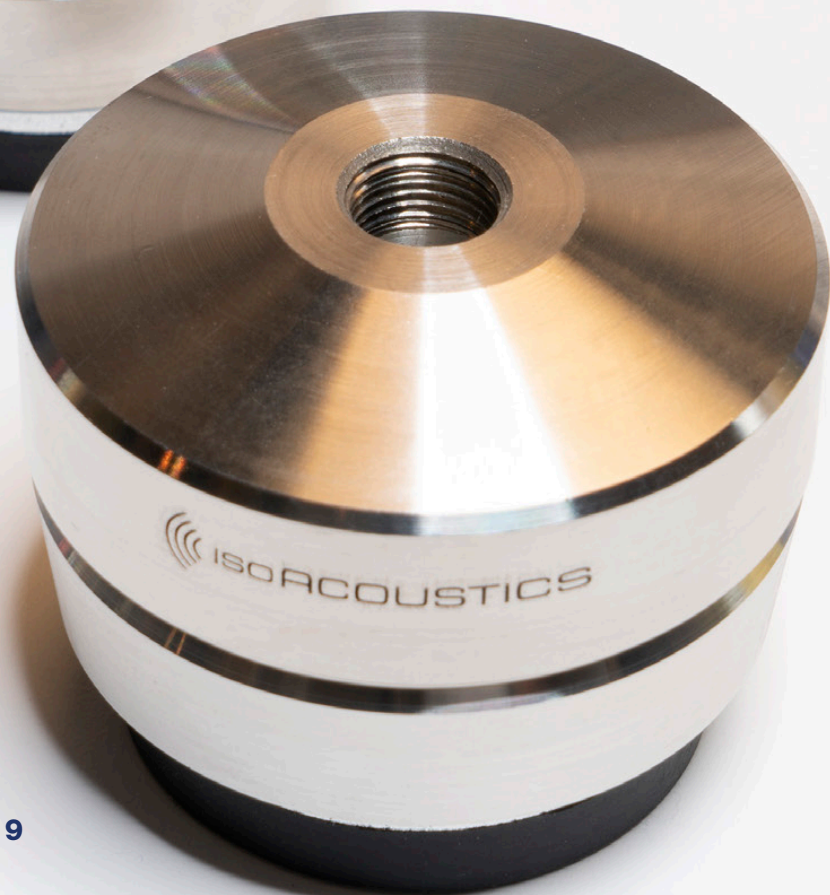

No. 25

No. 25 commemorates a quarter century of our pursuit of perfect sound, while pointing to our next 25 years of building the finest sub bass systems available. No. 25 employs our most advanced design, engineering and craftsmanship, featuring our ultra-reliable 1,000watt amplifier, lightweight carbon fibre 15" driver and legendary filter sets, crossovers, and zero compression wireless connectivity.

Featured here is the No. 25 Line Array, three No. 25s arranged vertically, permitting bass to emerge more naturally as it propagates throughout the room, striking our sinuses, kicking at our chest cavities and rumbling along the floor with power and majesty. Welcome to the pinnacle of sound, 25 years in the making.

Join the Pursuit™ | rel.net



In House

The soundtrack of assembling the issue...



Discovered Again! Dave Grusin

Keeping the mid issue groove mellow, we stick with Direct to Disc for \$20. That's about all you need to plunk down for one of the records, on the Sheffield Labs label that was at the beginning of "the audio store demo era." In 1976 and 1977, this title was ubiquitous.



SCULPTURE A



A.4 Silver

A.3

A.4 Copper

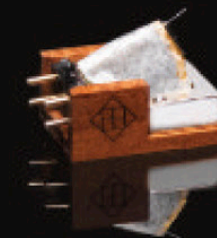

made by Ana Mighty Sound

LE PHONO SE

Working strictly as a class A single ended device with no feedback, our phonostage uses only solid state components (no op-amps) with the shortest signal path circuit possible.



Tailor built for your cartridge with carefully selected and matched high end components, it works with any MC cartridge from 0.1mV (74dB of gain) up to 2.5mV.

Le Phono SE, a solid-state design without the usual issues of tube electronics.

info@
anamightysound.com

A.3 & A.4 SCULPTURE A PHONO CARTRIDGES

Already awarded by French press with a « Remarquable » award, the A.3 and A.4 phono cartridges display a minimum tracking of 90 micron @300Hz lateral that will allow you to get the full definition of your records. For this we have developed a specific damper and use only boron cantilevers with dedicated geometry diamond tips.

With outputs from 0.1mV to 0.3mV with either silver or copper coils and impedances between 3 to 40 ohms.

It is the perfect companion of our Le Phono Single Ended phonostage and others.

With a compliance of 12 @100hz and three bodies, mixing impregnated wood with pure brass, copper, silver or gold, we are able to fine tune the weight and fine tune the sound of your cartridge to match perfectly the mechanics of your tonearm.

The A.3 is a fixed characteristic design, the A.4 is a tailor made cartridge up to your requests.

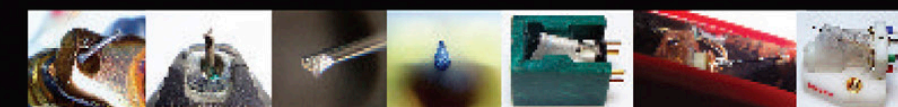

retip

Our insights on cartridge "repairs"

What if each cartridge was restored as unique artefact? We do not believe that glueing a cantilever and diamond tip is enough. Aging has an effect on your cartridge as well as usage wear, dust, hygrometry and UV.

Cartridge service : your cartridge does not sound as good as you remember? The damper might have been tampered with, the azimuth of your diamond tip is starting to be off or maybe the piano wire is getting loose?

We can check it out and get back the original parameters without altering the parts of your cartridge.

Fine-repair : we are able to completely rebuild Neumann DST (or Lumière), Clément cartridges and most MC cartridges available. Open coils? Stiff damper? Broken cantilever? We know how to deal with these issues and will do our best to get your cartridge as close to its original status, even though we can certainly alter your cartridge up to your requests.



MINE: it should be yours

Afriti Fez
\$60

fez-o-rama.com

You know how the song goes, "don't do it without the Fez on." The folks at Fez-O-Rama have short, medium, and tall ones, in a wide range of colors. They also have multiple tassel options.



Optimized or Compromised?



With the modular OCTAVE HP 700 preamplifier, there is no trade-off!

With the OCTAVE **HP 700** tube preamplifier there is no sacrifice of personal customization to enjoy perfect sound quality. Distinguished by its powerful and airy sound, the **HP 700** also boasts the incredible flexibility of eight optional high-end input modules, allowing perfect customization to any system without a hint of audible compromise.



Crafted from the highest grade components



Audiophile tone control option



Perfectly optimized optional input modules

OCTAVE

MODERN CLASSIC

The Classic SB
VINTAGE DESIGN MEETS MODERN TECHNOLOGY



We have turbocharged our EISA Award-winning “the Classic” to bring you this upgraded package - The Classic SB. It includes key new features:

- Electronic speedcontrol
- Sumiko Blue Point No.2 cartridge
- Top grade Clamp It
- Leather It mat

ELECTRONIC SPEEDCONTROL



SUMIKO BLUE POINT NO.2 CARTRIDGE



For more information, visit www.pro-jectusa.com

Setlist: Photo by Jeff Dorgay



Todd Rundgren. Revolution Theater. Portland, Oregon. May 27, 2019.

Breaking it up into two sets, the wizard that can sometimes be reluctant to play the hits, dove right in, playing his most accessible material all night long.

- | | |
|----------------------------------------|-----------------------------|
| 1 I Think You Know | 15 Love of The Common Man |
| 2 Open My Eyes | 16 Compassion |
| 3 Hello It's Me | 17 Couldn't I Just Tell You |
| 4 We Gotta Get You a Woman | 18 Fair Warning |
| 5 I Saw The Light | 19 The Individualist |
| 6 It Wouldn't Have Made Any Difference | 20 Eastern Intrigue |
| 7 Black Maria | 21 Buffalo Grass |
| 8 An Elpee's Worth of Tunes | 22 Tiny Demons |
| 9 Sometimes I Don't Know What to Feel | 23 Lost Horizon |
| 10 Too Far Gone | 24 Determination |
| 11 A Dream Goes on Forever | 25 Cliché |
| 12 The Death of Rock And Roll | 26 Bag Lady |
| 13 Can We Still be Friends | 27 The Want of a Nail |
| 14 Real Man | 28 Fade Away |

COVER STORY

Luxman: Stunning separates

\$14,995 each

luxman.com

Look at them, right up there on the front panel, bass and treble controls. I know real audiophiles don't need tone controls (actually, you probably do) but the +/- 8 dB at 100 Hz and 10 kHz work incredibly well when you've got that recording that's ever so slightly bright, or thin, or... I don't know about you, but I've got more than my share of records that could use a little bump or cut. Switching them in and out at least a hundred times, I can't hear a sonic difference, but goosing the bass a tad on Deep Purple's *Made In Japan* rocks. "Smoke on the Water" never sounded better. Almost all of my Todd Rundgren albums sound flat and thin, but 1db of treble cut and 3db of boost on the bottom end makes it a lot easier for us to be friends. Weather Report's *Heavy Weather* needed some help too. Once you get used to this increased flexibility, you may never go back.

My favorite thing about Japanese culture is the attention they pay to even the most minute detail, and the way that things are always done in a purposeful manner. Those of you that are equally detail-oriented will love Luxman products - and their C-900u control amplifier and M-900u power amplifier (which can be used as a monoblock as well) are fantastic examples of this philosophy.

Much like Luxman's PD-717 turntable that we reviewed last year, just taking it out of the box is somewhat of a ritual. I've never unpacked components that have been put in their boxes with the level of care that Luxman components are packed - not even Apple products are at this level.

Tactile and functional excellence

Getting past the initial excitement of unboxing these components, the way they genuinely integrate into your system, into your life is what makes them so lovely. Around the back panel of the M-900u sits the most useable speaker binding posts ever made. Where a few other premium manufacturers use winged binding post knobs, these are knurled round items. The most massive cables you can think of will work effortlessly with the M-900u. However, you can't use banana





ends with these binding posts, only spades.

Where a few other manufacturers that do offer power output meters go big, and Nagra goes really small, the M-900u offers modest sized power output meters, tucked off to the left-hand side of the faceplate, gently lit and just big enough to see from the other side of the listening room. Thoughtfully, a switch is on the front panel to turn them off, but why would you want to?

As you move both pieces to your equipment rack, pay careful attention to the metalwork. The precision in the cuts of the ventilation vents, the openings for the power meters and the control knobs are exquisite. Only Boulder and Burmester produce casework with this fine of a finish, and they are both considerably more expensive than these two pieces from Luxman, which both have an MSRP of \$14,995.

The C-900u offers the same level of fit and finish, along with a high level of human engineering. In addition to the tone controls, the front panel has the input selector and volume control larger in size and more centrally located for ultimate convenience. Even the remote control is just right in terms of size, with nothing left to chance. All inputs have a volume trim and phase preset and can be adjusted via the remote.

Good as the casework is, the same level of detail is taken with the components used, from the 1250VA power transformer, all the way to the signal wire going to the speaker binding posts. Even the feet are machined and optimized for maximum vibration control.

Though the trend in front panel displays tends to be blue these days, the C-900u's fluorescent

that is very easy on the eyes. Again, it's a color you want to leave on when listening. An added benefit, Luxman offers a zoom mode, that makes it even easier to see volume level, no matter where you are in the listening environment. Finally, on the back panel of the C-900u, every single input and output jack is covered with a light grey cover bearing the Luxman logo.

Both components are fully balanced, with the M-900u offering XLR and RCA inputs, with the C-900u offering three inputs and two inputs, each having XLR and RCA options. There is also a set of RCA inputs labeled "external pre-in" to use in a theater setup. Onboard phono is not included, for that, you will need to use a phono stage of your choice or one of the offerings from Luxman. (hint, hint, their EQ-500 is on its way as you read this.)

Perfect synergy

Of course, the M-900u and the C-900u work perfectly together, as you would expect from any manufacturer. Should your Luxman experience not start with both amplifier and preamplifier, rest assured that both separates should work equally well with whatever else you have in your system right now. You can get the complete specs for input and output impedance here, on the Luxman website.

Suffice to say, we matched the C-900u with power amplifiers from Pass Labs, McIntosh, Audio Research, Conrad-Johnson, Nagra, BAT, and PrimaLuna - balanced and unbalanced, all worked perfectly together. The converse goes for the M-900u - trying it with about eight different preamplifiers, all yielded great results.

The sound

Both of these components sounded dynamic and alive right out of the box, opening up only slightly after being powered up for 48 hours, and not really changing much more with weeks of play. The last generation of Luxman flagship power amplifiers were full class-A, the current M-900u is now a class AB amplifier, but it offers more power than the model it replaces, producing 150 watts per channel into 8 ohms, and able to generate 1200 watts per channel into a 1-ohm load.

We were not able to verify this, but my vintage Magnepan Tympani IV speakers go down to about 3 ohms and are incredibly power hungry. The M-900u was able to play these problematic speakers to room-filling volume without issue, and without generating extreme heat either. Though the Quad 2812s are not terribly power hungry, they tend to give a more expansive performance with amplifiers that can deliver a lot of current, and present a somewhat capacitive load. Again, the M-900u sails through this torture test.

Where the past generation of Luxman Class-A monoblocks had a slightly warmer presentation, more like that of their 590 series integrated amplifiers, the M-900u/C-900u is more neutral in tonal value, with perhaps just a slight touch of warmth. All but those having incredibly forward sounding speakers or a room with an excess of high-frequency energy will feel right at home with these two components. Because of this voicing, they blend into the background, putting you right into the musical performance and serve the music - as it should be.

In my primary system with the mighty Focal Stella Utopia EM's and the Quad 2812 speakers



The Luxman M-900u and C-900u

(with six pack of REL no.25 subwoofers - review in the works) the sound field generated is enormous in all three dimensions. Playing bass heavy tracks reveals power, control, and texture, and when listening to acoustic instruments, not only is the timbral information rendered accurately, the spatial information is as well. Nothing is bombastic, violins sound like violins, not six-foot tall violins.

Going all the way back to George Winston's December, on vinyl, his piano comes forward with the necessary amount of sheer acceleration to convince your brain that you are really listening to a piano (again, kudos to the Focal's for some help here) and the decay is breathtaking. This is what world class components offer, and that this level of fidelity is available at the price point of these two components is out of this world good.

Close to the edge

The Luxman pair does not lose composure when pushing the level meters to full output, and a little beyond. Even when listening to very dynamic rock and classical pieces at a reasonably high level, it was impossible to achieve clipping on anything but the Magnepans - and then it was not harsh, more of a flattening. On most speakers, your ears will relent in pain (or at least a little buzzing) before you push the M-900u too far. For those of you that need still more, a simple flip of a switch turns them

into monoblocks, capable of delivering twice as much power, with up to 2400 watts per channel available at 1 ohm.

Luxman mentions new gain stages that utilize a minimal negative feedback (they call it ODNF version 4.0) and the improved, LECUA 1000 attenuator circuit, that offers adjustment from 0db to 87 dB in single dB steps. It all works together to provide a neutral, yet airy rendition that is resolving enough to be engaging and smooth enough to be fatigue-free - a tough balance to achieve, especially for solid-state components. It has to be said that Luxman is one of the masters of the genre, no doubt depending on the same engineers that voice their tube components.

Understated value

While \$30,000 is not a pittance by any stretch of the imagination, in the greater context of what is available at the top of today's audio market, I consider both of these Luxman components an Exceptional Value, worthy of our award, but the pair together is even more. Taking into account the obvious synergy and similar voicing, this is an amplifier and preamplifier that is a solid "end of the audio journey." Thanks to the ability to turn the M-900u into a monoblock and expand the sound you love, should your taste in speakers change solidifies this even more.

Well done, Luxman.



Peripherals

Analog source

Grand Prix Audio Monaco/Tri Planar, Koetsu Jade Platinum, Luxman PD-717/Kiseki Purple Heart

Phono stage

Pass Labs XS Phono

Digital source

dCS Vivaldi One

Speakers

Focal Stella Utopia EM

Cable

Cardas Clear, Tellurium Q Statement



The Van Alstine SET 400 Power Amplifier

\$2,000?

avahifi.com

While so many know Van Alstine for their vintage Dynaco mods, owner Frank Van Alstine has been designing and building his own components for decades. Everything we've had the opportunity to listen to has been at the top of its class, providing outstanding sound and value.

Van Alstine takes a pass on aesthetics, putting every penny inside the box, but to be fair AVA has stepped up their game in their recent round of products, shedding the "modder" look. But you don't buy Van Alstine for fancy casework. Staying true to their original design ethos, the SET 400 comes in just under \$2,000, in a black, Ha-



Mu-so 2nd Generation LUXURY DESIGN & MORE MUSIC POWER

Introducing the New Naim Mu-so 2nd Generation

Mu-so 2nd Generation evolves the iconic styling of its predecessor, but under its luxury aluminium casing are game-changing performance, feature and functionality upgrades. From high-resolution streaming to multiroom music to TV sound; you've never heard it so good from an all-in-one wireless system.



The AVA Vision SET 400 Amplifier

The Good:

Tons of power

Bargain price

Top shelf reliability

Great sound

Not so much:

Spartan aesthetics

The Verdict:

Another Exceptional Value Award winner

fler-like front panel and rocker switch for power. The upgraded cosmetics you see here are only an additional \$200—an excellent way to give the performance-oriented audiophile trying to maximize every dollar an option.

Van Alstine takes a pass on aesthetics, putting every penny inside the box, but to be fair AVA has stepped up their game in their recent round of products, shedding the “modder” look. But you don’t buy Van Alstine for fancy casework. Staying true to their original design ethos, the SET 400 comes in just under \$2,000, in a black, Hafler-like front panel and rocker switch for power. The upgraded cosmetics you see here are only an additional \$200 - an excellent way to give the performance-oriented audiophile trying to maximize every dollar an option.

We’ve always been fans of Mr. Van Alstine’s designs, but he’s really outdone himself on the SET 400. This amplifier is powerful yet delicate. A tough benchmark to hit for expensive solid-state amps, but unheard of for \$2,000. Overall tonal balance is very neutral but easily warmed up for those wanting that sonic signature with a tube preamplifier. For many of us, a tube preamplifier and big solid state power amplifier have always been a quick way to nirvana without buying a lot of power tubes.

Mated with a vintage Audio Research SP-11, borrowed from staffer Jerold O’Brien, the SET 400 is positively heavenly with our vintage Magnepan Tympanis. If you’ve been looking for a killer Magnepan amplifier that doesn’t break the bank, there is nothing better at anywhere near this price.

Equally great results were had with speakers from Focal, JBL, (the new L-100 Classics) Paradigm, and Raidho. There’s nothing the SET 400 won’t drive with ease. Even with something smaller, like the KEF LS-50s (notoriously power hungry) Harbeths and various LS3/5A speakers, the control provided by a high power amplifier is tough to ignore.

Please click [here](#) for Rob Johnson’s full review.



The PS Audio DirectStream Power Plant 20

It will take less time to hear the improvement it makes, than it will to read this headline.

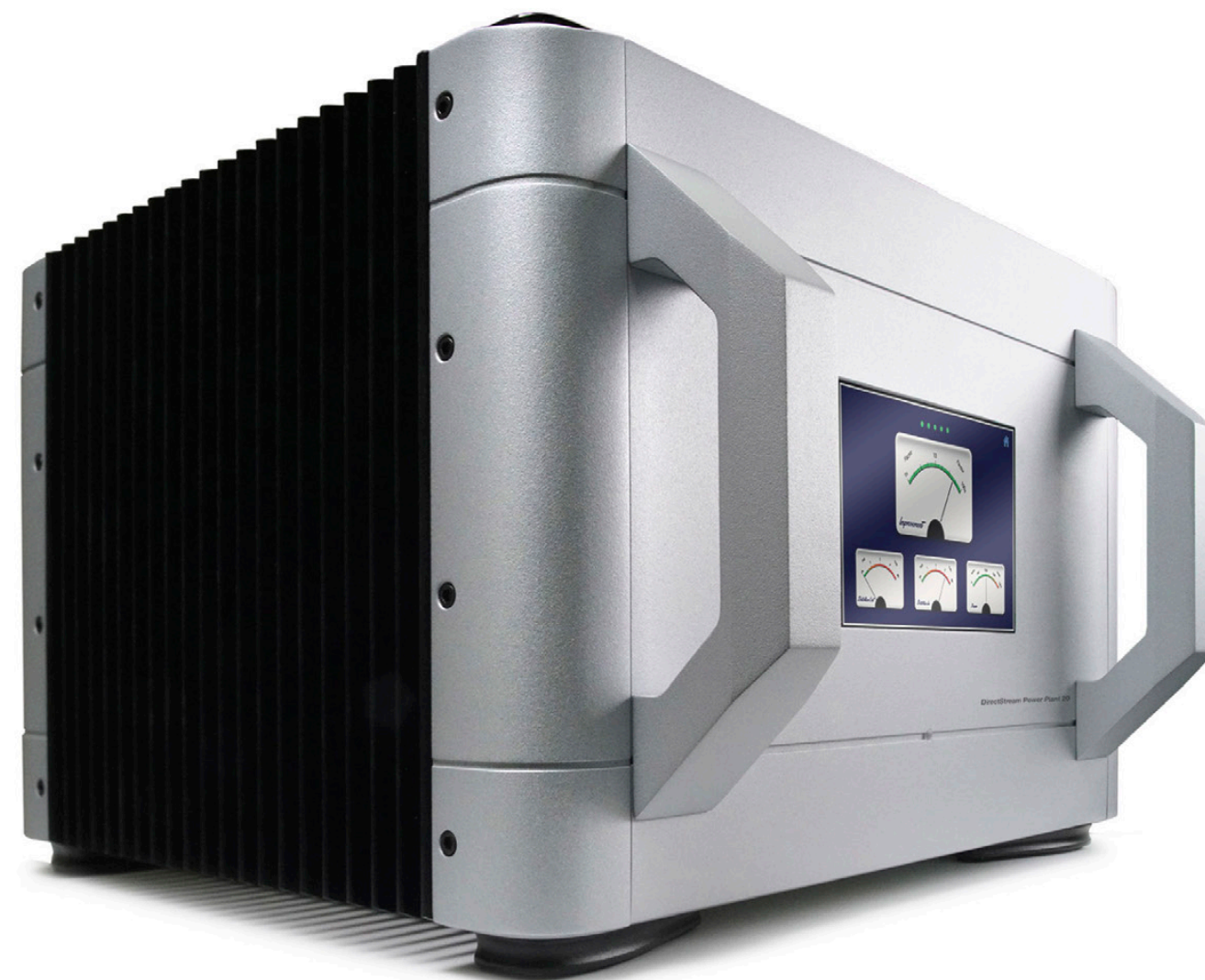

“Nothing does a better job at supplying clean power to my reference gear than the P20.”
—Jeff Dorgay, TONEAudio

 P S A U D I O

www.psaudio.com 720.406.8946 Boulder, Colorado

Bryston 28B Cubed Monoblocks

\$11,995 each

bryston.com

by Jeff Dorgay

Audio enthusiasts are often torn between the nuance of a small amplifier, (often due to a more simple circuit design) and the sheer heft and control of a big amplifier. For some, the sensitivity of your speakers will determine the route you should go. If you have low sensitivity (86db/1-watt or lower) speakers, you'll need to seek out high power or live frustrated by a lack of control and dynamic range. Those with speakers having a high sensitivity (94db or greater) are wasting the capability of a high powered amplifier, and perhaps wasting money as well.

The new 28B "cubed" amplifiers from Bryston weigh in at over 100 pounds each and tip the price scale at close to \$24k/pair. This is big dough for Bryston, who's made a reputation on modestly





The Good:

- Power beyond belief
- Exceptional musicality
- Will outlive you
- Lovely industrial design

Not so much:

- Heavy, get a friend to help with the lifting

The Verdict:

Bryston has built a winner with the 28B cubed amplifiers. Nothing can touch these in terms of performance for the price. Just be cautious with the volume control. These produce so much clean power, a dB meter might be a good thing until you get used to just how loud they can play.

Bryston 28B Cubed Monoblocks



Audio enthusiasts are often torn between the nuance of a small amplifier, (often due to a more simple circuit design) and the sheer heft and control of a big amplifier. For some, the sensitivity of your speakers will determine the route you should go. If you have low sensitivity (86db/1-watt or lower) speakers, you'll need to seek out high power or live frustrated by a lack of control and dynamic range. Those with speakers having a high sensitivity (94db or greater) are wasting the capability of a high powered amplifier, and perhaps wasting money as well.

The new 28B “cubed” amplifiers from Bryston weigh in at over 100 pounds each and tip the price scale at close to \$24k/pair. This is big dough for Bryston, who's made a reputation on modestly priced gear that delivers heavily on performance and reliability. Their products carry a 20-year warranty, and a cursory poll of the TONE staff and close friends doesn't turn up a single person that has ever had a Bryston product fail. The only other amplifiers we've had that luck with in TONE's near 16-year history is Nagra and Pass Labs. Everything else we've owned has been back to the shop at least once over the years.

Assuming that your favorite power amplifier (that probably weighs 100 pounds or more) is going to cost around \$500-\$700 with insurance to make a round trip for service, just this aspect of Bryston ownership goes a long way at justifying the price.

Should that not be enough to convince you, perhaps the great sound and the fact that these amplifiers can produce 1000 watts per channel into an 8-ohm load and 1800 watts per channel into a two ohm load. You could power a PA system with that much power. (some sound reinforcement companies do.)

Power and reliability are great, but the recent cubed version of Bryston amplifiers bring a much higher level of sheer musicality to the table. Where the past Brystons have always been tonally honest, they've been accused of being slightly uninvolved by some. Those days are over. These are wonderful amplifiers. They play great quiet and they hold their composure at high volume. We couldn't play anything loud enough to hear even a hint of strain, fatigue, or distortion. And, for those who have found Bryston amplifiers a bit visually sterile, the new cubed series features stunning, thick, machined faceplates that are beautifully finished. The dilemma is to get them without handles and admire them even more, or to get the handled version, because that makes them a little easier to carry around and move into place. Make no mistake, the 28B cubed amplifiers are world class—visually and sonically. They just don't cost crazy money.





Roon Nucleus and Nucleus+

\$1,399 and \$2,499, respectively

roonlabs.com

You can fuss with all the other music cataloging and delivery platforms out there, or you can get Roon. If keeping track of all the music in your life, resident on your NAS drive(s) and in the streaming realm, there is nothing better. Roon runs on a Mac or PC, and it can even run in the background while you're using your machine for other stuff.

However, you won't get the maximum performance from the Roon interface, especially if you have a large library, take advantage of Roon's DSP options, or are running Roon in multiple zones simultaneously. It takes a fair amount of processing power to keep track of all those tracks.

You may even progress to dedicating a single computer to run your Roon core, but even that is an interim solution, with its own limitations. Again, the larger your collection, and the more you are keeping track of from streaming services, the more it taxes the software's ability to juggle everything. If you have a couple hundred discs ripped on a local drive and are maybe following a couple hundred more, you don't need a Nucleus.

But for the rest of us crazed music collectors, you've probably noticed that running Roon on your Mac mini is starting to get slower, and slower. You've also noticed just how much it costs to buy a new Mac mini these days. Forget about that, come on over to the other side.

Pure legacy. Next-gen attitude.



**We've taken care of the tech.
You take care of the music.**



The new Dynaudio Xeo wireless stereo speakers: all the performance of high-end hi-fi with none of the hassle. Just plug them into the mains and plug in your sources – or stream with high-quality aptX Bluetooth. It's as simple as that.

DYNAUDIO
Xeo 20 / 30

dynaudio.com

Roon Nucleus and Nucleus+

The Good:

The world's biggest record store 24/7

Integrates your NAS and streaming content seamlessly

So easy to use, they don't even print an instruction manual

Lightning fast response, no matter how large your music collection

Not so much:

Some will balk at paying \$20/month for the service.

The Verdict:

There is no better, faster, easier way to access digital music than ROON. Isn't that worth a few latte's a month?



The Roon Nucleus is a purpose-built hardware solution with a proprietary OS, optimized for said hardware. It's not meant to be used for editing photos or answering email. It does nothing but run your Roon core at lightning speed. Though both the Nucleus and Nucleus + look identical in size, the + has more performance bandwidth, suggested for users with more than 10,000 albums in their collection, where the standard model is for 10,000 albums and under.

It works flawlessly, and we'll go as far as to say that you haven't experienced the true pleasure of Roon if you're running it on a Mac or PC.

You can read the rest of our analysis [here](#). 🎵



The Vitus Audio RI-101 Integrated

\$15,600 (amplifier), DAC/Streamer module (\$5,000 additional)

vitusaudio.com

Forget about the vinyl resurgence for a minute - but just for a minute! Another significant resurgence that's snuck upon us is that of the integrated amplifier. In the 60s and 70s, substituting the receiver with a tuner/integrated combo was seen by many as the gateway to a rack of separate components. It also allowed the user wanting more power, to buy a more powerful integrated amplifier and do a minimum spend on the tuner, if that was the preference, or not at all.

Today, with streaming audio putting the FM tuner into near extinction, the integrated is back with a vengeance. With so many premium manufacturers bringing their expertise to bear, current integrations sound as good as, and in some cases better than separates. This solves two problems:

first—one no longer need to agonize over the cable between the amp and pre, second - impedance matching and compatibility are assured. Not to mention the space saving aspect.

Some manufacturers are actually taking us back towards the functionality of the almighty receiver, combining phono sections, and now streaming DACs are on the chassis as well. The obvious argument is the worry over individual sections becoming out of date, and the resulting horror of having an integrated amplifier with a DAC or phono stage that no longer is up to par.



Vitus Audio takes a more forward-thinking approach. They have left the phono stage out of their integrated amplifiers, and allow you the option of ordering a streaming DAC that can handle all current digital files as a plug-in option. In the event of a unit failure, or a significant upgrade to digital capabilities, one merely unplug the digital module and make the change. This is a big step in future-proofing their product and should be welcomed by all.

Tipping the weight scale at just under 85 pounds, and the price scale at just under \$20k with streaming DAC module installed, their RI-101 can hardly be called entry level. While it is at the bottom of their range, this is an excellent combination sonically, and better than many companies' flagships.

With 300 watts per channel, the RI-101 drives any speaker, with authority, and because it is not a full class-A design, will not use quite as much power or generate as much heat as the

giant Vitus monoblocks. Chances are at modest volume levels, you'll still be listening with the amplifier biased in class-A mode, so you are reaping the benefits of their finest amplifiers.

The onboard, streaming DAC decodes everything and is a Roon endpoint to boot. World-class audio is only five minutes away from unboxing. Plug it into the wall, connect your speakers and an Ethernet cable. Tell ROON where to send your music and press play. Done. Add a few more minutes if you have a turntable and phono preamplifier.

Top quality sound doesn't get any easier than this. For all but the most obsessed audiophile, the RI-101 is a destination product. For the rest of you, Mr. Vitus has a full line of components that go as far as your bank account and biceps can handle.

Please click [here](#) to read our full review. 



PrimaLuna HP
The World's Finest Tube Integrated \$4399



LUMIN
The finest streaming DACs made today.
All models in stock now.

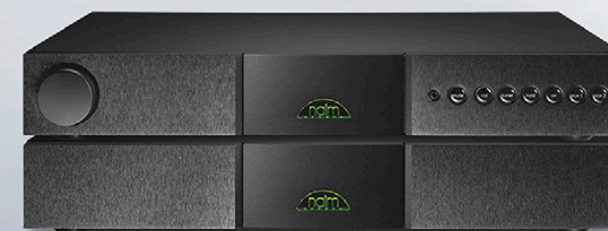

NAIM Preamp/Poweramp Bundle
We bought them all to get you this price! ~~\$5990~~, \$2249



KISEKI
Purple Heart N.S.
~~\$3499~~ \$3199

FOCAL
Electra 1038 Be
Launched at \$12,450.
One of our bestsellers.
While supplies last.
\$6999



VPI Classic 4 Package
\$1000 Periphery Ring & 12" 3D Tonearm - ~~\$11700~~, \$5999



Upgrade to Focal Headphones.
We pay top dollar on all trades.
Exciting bundles available!



FOCAL
All Models in Stock

View a huge selection of used items on our website! We take trade-ins!

IN STOCK: ACOUSTIC ZEN, ANTHEM, AUDEZE, AUDIOQUEST, AURALIC, BALANCED AUDIO TECHNOLOGY, BELLARI, BENZ MICRO, BLUESOUND, BOWERS & WILKINS, BURSON AUDIO, CARY, CLEARAUDIO, DH LABS, DR. FEICKERT ANALOGUE, DYNAVECTOR, EAT, FOCAL, GRAHAM, HANA, HIFIMAN, ISOACOUSTICS, ISOTEK, JL AUDIO, KEF, KIMBER KABLE, KISEKI, KLIPPSCH, KOETSU, LEHMANN, LUMIN, LYRA, MANLEY, MARTIN LOGAN, MONITOR AUDIO, MUSICAL FIDELITY, MUSIC HALL, MYSTÈRE, MYTEK, NAD, NOLA, NORDOST, ORTOFON, PANGEA, PEACHTREE, PRIMALUNA, PRO-JECT, PS AUDIO, REGA, REL, ROTEL, SHELTER, SONUS FABER, SOUNDSMITH, SUMIKO, SUTHERLAND, TANNOY, VPI, VINCENT, AND ZESTO AUDIO

909-931-9686
upscaleaudio.com



The Vitus Audio RI-101 Integrated Amplifier

The Good:

Single box, premium sound

Fantastic on-board DAC/Streamer

Modular approach offers easy upgrade path

Great way to enter the Vitus family

Not so much:

None

The Verdict:

Vitus has leveraged their engineering and build capabilities to produce an amplifier challenging many separate components for a fraction of the price.



**If this isn't what your system sees,
You're doing it wrong...**

EXO GAL, LLC 4657 Aspen Ridge Circle, Eagan, MN 55122
651-964-0698 exogal.com info@exogal.com



Playlist:

What Our Readers Are Into

Tone Playlists are sponsored by...



Mark Knopfler—Boom, Like That

John Hiatt—Down Around My Place

Rainbow—Stargazer

Robert Plant—Carry Fire

Tom Petty and the Heartbreakers—
When the Time Comes

Sugartooth—Sound of Her Laughter

In Exile—The Pineapple Thief

Bad Religion—Nobody Listens

Peter Gabriel—Mercy Street

Porcupine Tree—The Creator
Has a Mixtape



Staffer Michael "Muppet" Laurance has another great list of tracks for us this issue.

audio physic

No loss of fine detail

The NEW Audio Physic Step plus

"If you want a highly immersive, three-dimensional music experience in a small to modest room, these are the speakers that should be at the top of your list... There is amazing amount of technology incorporated into the speakers, something pretty much unheard of at this price point. ... a highly resolving look into the music presented without ever being harsh, strident or fatiguing and that is a tough balance to achieve."

These speakers sounded almost magical...It was quite uncanny. They are high-end speakers... that out perform many speakers in their size class."

Mel Martin
Secrets of Home Theater and High Fidelity

Jeff Dorgay Tone Audio

 VANA LTD
vanaltd.com

The Nagra Classic Power Amplifier

\$16,595

nagraaudio.com

Nagra is much like the Swiss watch manufacturer Rolex, in the sense that they are such a vertical manufacturing company, with incredibly high precision. Nearly everything is made in house, keeping a tight rein on quality at every turn. Once, on a visit to the Nagra factory, Matthieu LaTour (Director of Nagra's Audio Division) told me that they even used to make the screws in house, "but that got a bit too expensive."

One of the most exciting aspects of watching a Nagra component come to life is the installation of their famed modulometer – the circular output meter that displays both channels in a gently backlit yellow glow. The care that goes into the construction of this meter eclipses that of any mass market component and has been a Nagra standard since the company's beginning. And yes, the audio purists that can't be interrupted by any lights during their listening session can turn this light off via a front panel switch. We prefer to bask in the glory of the meter.

SWITZERLAND 



Nagra components are made with a sense of care, passion, and attention to detail. When finished, performance is confirmed with the same rigorous diligence, assuring that when these works of audio art get to your door, they will perform flawlessly for generations.

The sound produced by all Nagra components is uncolored, and while their top HD range has been gaining acclaim at all the world's top audio shows, the Classic components share the same lineage and are incredible in their own right. Some prefer the larger, full-sized (at least by American standards) casework of the HD components, but the Classic line is perfect for the music lover wanting high performance in a more compact form factor. Though deceptively small in physical size, there isn't a square millimeter of wasted space inside the Classic

Power Amplifier, and removing the top reveals a massive power transformer. 300,000uf of filter capacitors assures smooth, noise-free current is delivered to all stages of amplification. Your perception will change when you lift the Classic Power Amplifier – it weighs 39 pounds, 10 ounces. (Swiss precision, you know...)

The Classic Power Amplifier offers XLR and RCA inputs and produces 100 watts per channel. Just in case you need to achieve the sound pressure levels of the Montreux Jazz Festival (of which Nagra has long been involved) the Classic Power Amplifier can be bridged via the switch on the rear panel to produce twice as much power in a monoblock configuration. Though our reference Sonus faber Stradivaris are relatively sensitive, the urge to play "Smoke on the Water" at an Earth-shattering level proved too hard to resist. Most of you will be just fine with a single Classic Power Amplifier, but it is nice to know that there is a simple upgrade path should you need it. One upgrade that is worthy of adding at the beginning of your Nagra journey is their VFS platform, built to decouple the Classic Power Amplifier from whatever surface it is installed. The VFS has a retail of \$2,495, utilizing two finely machined layers of stainless steel, machined and anodized with the same level of finish as the rest of the Nagra lineup. These plates are coupled to each other and to the shelf they rest upon with different dampening materials, developed from aerospace research. Considering the price that so many premium audio racks command

NAGRA CLASSIC AMP



Essential Elements.

The Element range is the starting point in our product line-up. But we view it as essential to getting a great performance from your kit.

It seems the world's hifi press agree. We've won a lot of awards for Element, including What HiFi's 'Best Analogue Interconnect' for the last 3 years.

We apply as much innovation and effort to the Element Series as our top of the range Asimi.

The 'Integra' low mass RCA connector was originally developed for the Element cable and the principles applied throughout our range.

Our latest Element sc USB cable is based on research showing solid core cable delivers superior results to conventional multi-strand.

Element cables are available for hi-fi, personal audio, digital & video use.



Distributed in North America by:
www.integrityhf.com



Enjoy the Experience



PASS

Pass Laboratories
13395 New Airport Rd. Ste G., Auburn, CA 95602
(530) 878-5350 - www.passlabs.com

The Nagra Classic Power Amplifier



these days, placing your Nagra component on top of a VFS makes these racks irrelevant. We have used them to excellent result here with all Nagra components, and it takes but 30 seconds to hear the improvement in clarity that they provide.

Thanks to the Classic Power Amplifier, delivering lower level output in Class A mode, transitioning to AB at high power, the combination of smoothness and unwavering dynamic capability is tough to beat. At comfortable listening levels, you will most likely be listening in Class A mode, yet this amplifier barely gets warm to the touch. You can read our full review here, and as an added bonus, we are working on a comprehensive evaluation of the entire Nagra Classic lineup. This is only the beginning of our analysis and will be completed with a full system review. Suffice to say that the whole system is fantastic, and we look forward to sharing it with you in the months to come. Much like that famous Swiss watch company, once you dig beneath the surface and live with Nagra for a while, you realize just how much technical excellence lies beneath the surface, and what a real value these components really are.



The Good:

- Sleek styling and compact form factor
- Top build quality, marvelous attention to detail
- Scaleable, can be configured as monoblocks
- Fantastic sound

Not so much:

- Some may be wary of the compact shape

The Verdict:

Nagra has been building some of the world's finest components for some time now, and the Classic series is fantastic. The Classic series is perfect for anyone wanting high performance audio delivered by components that don't take over the listening room. Once you get used to the way Nagra does things, it will be hard to resist acquiring the rest of the system.

Can't get it out of my Head By Emily Duff

It doesn't take much of a push or a prayer to get me listening to Gospel music, or as I like to call it Hallelujah Music. Some people call it Praise Music, others find Spiritual to be the proper term. Whatever you dig, I have faith that you will recognize these tunes and these artists because they are some of the finest singers and performers that have ever lived.

As a matter of fact, Aretha Franklin's *Amazing Grace* is the best selling gospel record of all time and right now you can, (and I did) go see the recently released, much anticipated, documentary concert film of the same name, about the recording of this incredible record. It's a trip into

the past and the humble church-life beginnings of the Queen of Soul, with a wink and a nod to her father, the Rev. CL Franklin. From the lead off "Mary Don't you Weep" you are welcomed into the California church and no matter what is laying heavy on your mind, this record will set you FREE. It earned Aretha a Grammy in 1973 and there is no doubt that James Cleveland and The Southern California Community Choir had much to do with that. This record is never out of my head. The band is PERFECT, soulful, rockin' on all fronts and the vibe is pure JOY. Special love for the 10-minute version of "Amazing Grace," a song we think we all know and might never need to hear again. Think again. This version will slay



FOCAL
LISTEN BEYOND

THE POWER OF STYLE

Focal showcases the beauty of wood on its loudspeakers

THE DELICACY OF OAK FOR SOPRA

The smooth, uninterrupted lines of Sopra No 2 and No 3 are enhanced by the creamy combination of an ivory front with light oak sides and the rich pairing of a chocolate front with dark oak sides. The naturally light wood shines under Focal's signature high-gloss finish.

THE SPLENDOR OF WALNUT FOR UTOPIA

For the prestigious Utopia III Evo, Focal acquired a batch of exquisite French walnut cultivated from a century-old tree in the Ain region. Sealed beneath a satin finish, this brown-veined tawny yellow wood exhibits stunning nuances of color and character amongst its plentiful knots and irregular grain. Scala Utopia Evo and Maestro Utopia Evo are both available in an elegant light finish or an extravagant dark finish.

MADE IN
FRANCE

By Emily Duff **Can't get it out of my Head**

you over and over. Amazing doesn't even begin to describe what this album is. Grace is what Aretha teaches us with every gorgeous note and nuance.

This year I put out a Gospel record myself and you better believe I can't get THAT out of my head. However, a huge part of my wanting to put out this collection of songs had everything to do with The Lord Will Make a Way by Al Green. This is some Funky Jesus! Al had me at "Let's Stay Together" but this record is more like "Let's Stay Righteous." This record takes Al Green out of secular music and into Gospel – complete with disco strings, slap bass, and horns. Featuring Al's signature sweet, smooth vocal and B3 organ, this collection of 9 songs is accessible Gospel for anyone looking to get a taste of the Spirit with all the trappings of popular music, soulful and full of legendary studio players.

Bob Dylan.....You damn poet, you! Slow Train Coming is a record you either love or you don't. I love it. Each song is crafted to beautifully and organically. The performances are stellar and the sequencing is close to perfect. This album stands as one of the best records written about LOVE and FAITH. "I Believe in You" illustrates that perfectly - go ahead and cue it up and have a listen. The tunes are long, so there are only 9 Tracks lasting 46 minutes (a perfect album length) and remember, you "Gotta Serve Somebody," it might as well be Bob Dylan cause having these songs stuck in your head is a slow train straight to heaven.

Mahalia Jackson's My Faith is a love letter to Christianity with standard "jazz-like" arrangements. Each song feels like a creed or a blueprint for a righteous life and Mahalia sings it with such convincing sincerity and joy that you want to say "Amen" after each track. Going from the first



track, "My Faith" to the last, "Life Can be Beautiful," is a journey from Genesis to Revelations.

Larry Campbell & Theresa Williams' self-titled album might not be Gospel but I'll be damned if that record don't feel like religion. Track 10 "Keep Your Lamp Trimmed and Burning" is a Traditional "Spiritual" that has been given the Lazarus treatment here with Theresa's vocal which actually could raise the dead.

Staying in this groove, I'm assigning y'all some extra credit. I highly recommend Henry L. Carrigan Jr.'s brand new book, "Fifteen Spirituals that will Change Your Life" to read what he has to say. And maybe spin some Aretha while you're reading through!



THE COMPONENTS OF EXCELLENCE: LASTING VALUE

Before you buy a new audio component, consider why some people would rather own a used McIntosh than a new anything else.



Made in the USA

"The best source I know for all things McIntosh is Audio Classics in Vestal, New York. They do a lot of restoration work on McIntosh products and are an authorized McIntosh dealer and service center."

Jim Hannon, VP/Group Publisher & Senior Writer, *The Absolute Sound*

Timeless design. Legendary construction. Sound investment.

www.AUDIOCLASSICS.com
AUDIO • HOME THEATER • STEREO

3501 Vestal Road • Vestal, New York 13850 Call 607-766-3501 or 800-321-2834

Hours: Monday-Friday 8-5:30 EST - Other Hours by Appointment

TOTEM 
Discover yours

TORRENT 
TECHNOLOGY

The new V2 woofers are a dramatic advancement of our famous 7" Torrent driver. Evolved and meticulously developed over the past 10 years, exclusively by Totem, they are at the very top of the world's dynamic speaker pyramid.

The New Element Metal V2 ... A state-of-the-art musical experience!

MINE: it should be yours



**Casanuva Wooden
Omega Headphone Stand**
\$30
Amazon.com

A few years ago, there was a company making some very nice, but incredibly overpriced wooden omega stands. While we're not always in favor of knock off products, these stands work well. For the headphone lover with multiple pairs of favorite phones, this is a very cost effective way to show off your collection. At Amazon, of course!

Setlist:

Photo by Brian Gage



John Paul White. Mississippi Studios. Portland, Oregon. June, 18, 2019.

A small intimate club with good acoustics. A talented singer songwriter (ex-Civil Wars) with a great backing band. JPW conjured up the spirits of the great Roy Oribison, Glen Campbell and other songwriting greats, made for one unforgettable evening.

- 1 I Wish I Could Write You A Song
- 2 My Dreams Have All Come True
- 3 Long Way Home
- 4 Yesterday's Love
- 5 Heart Like A Kite
- 6 The Hurting Kind
- 7 The Good Old Days
- 8 This Isn't Gonna End Well
- 9 James
- 10 Simple Song
- 11 Hate The Way You Love Me
- 12 What's So
- 13 The Once and Future Queen (encore. JPW solo unplugged)
- 14 Can't Get it Out Of My Head (encore. ELO cover)

ESOTERIC

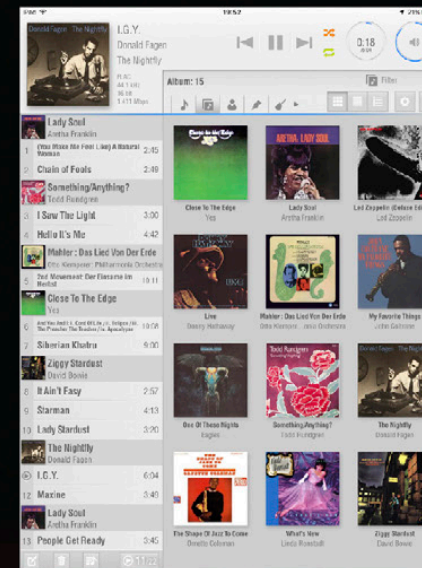

Esoteric SoundStream App

The Esoteric N-01 Network Audio Player, quite possibly the world's most versatile and best sounding Network Player / DAC. Featuring 35-bit processing, the ability to decode PCM, DSD, and even MQA files, the N-01 is driven by an easy to use interface that incorporates Tidal, Qobuz, Spotify and TuneIn as well as easy access to your NAS stored music. The N-01 is also fully Roon Ready.

No wonder TONE is recognizing the N-01 as the "TONE Product Of the Year" for Digital. We Thank the folks at TONE for this honor.



Quality Meets Quantity

“THE REL 212/SE DOES **DEEP** AND IT DOES **LOUD**. ODDLY, IT ALSO DOES **SUBTLE** AND IT DOES **BRASH**, TOO. AND SOMETIMES IT MANAGES TO DO BOTH AT ONCE. IF YOU TRULY “GET” DEEP BASS, IF YOU LIKE YOUR KIT TO BE ON SHOW RATHER THAN HIDDEN AWAY AND — ABOVE ALL — YOU FEEL THAT URGE FOR **TRULY ENERGETIC AUDIO**, THEN THE REL 212/SE IS ACTUALLY **GOOD VALUE**. ” | ADAM RAYNER, HOME CINEMA CHOICE

Join the Pursuit™

rel.net

Experience the 212SE's Twin long-stroke 12" Continuous Cast™ Alloy Bass Engines and dual 12" passives
Visit rel.net to learn more about REL and find an authorized dealer near you.

Future Tense

Reviews in our immediate future...



Totem Tribe Towers

\$5,500/pair

totemacoustic.com

Totem Acoustics Vince Bruzzeze is the king of getting big speaker bass and dynamics from modest size cabinets (often wowing hifi show crowds in the process), but the new Tribe Tower takes the Totem magic even further. This is a relatively small speaker that can blend into any décor that will have you looking for the subwoofer as soon as you power them up.

Future Tense

Reviews in our immediate future...



VPI Prime Scout

\$2,200

vpiindustries.com

Always improving the breed, VPI takes the lessons learned from their original Scout and Classic series, stirring in some of the DNA from their Prime series and creates the new Prime Scout. The result is a formidable table from America's top turntable manufacturer. Reviewer Eric Neff will be sharing his thoughts shortly on VPI's latest.



"no matter what I listened to, I couldn't imagine the sound being much better"
Soundstage! June 2017

Technology

Bryston's new patented Salomie Circuit is a revolutionary new way to reduce distortion and noise unveiling never before heard details only hinted at by other equipment. The input stage operates at distortion of less than 0.001 percent!

Power

Cubed Series technology is available in 10 different amplifiers ranging from the B135³ integrated at 135 watts per channel, the venerable 4B³ at 300 watts by two channels, to the incredible 28B³ 1000 watt mono block.

Control

For the first time, Bryston brings Cubed Series to the front end. Our new BP-17³ Preamplifier features the Salomie Circuit from input to output reproducing higher resolution than ever before.



Future Tense

Reviews in our immediate future...

JL Audio Fathom In-Ceiling Subwoofer system

\$2,300

jlaudio.com

We've used JL Audio's in-wall Fathom to great result, and their new, smaller 8-inch in-ceiling sub promises to be an even bigger hit, with even greater flexibility. Featuring a dedicated 600 watt amplifier, and DSP integration, this promises big bass in nearly any room configuration. We'll have a full review and install details.



LUXMAN since 1925

“The Ultimate”

Brings the Future to the Present
Preserves the Legendary Musical Pedigree



SUPER AUDIO CD PLAYER

D-08u



CONTROL AMPLIFIER

C-900u



STEREO POWER AMPLIFIER

M-900u

www.luxman.com

Future Tense

Reviews in our immediate future...



Bryston BP-2 Phono Preamplifier and PS-3 Power supply

\$1,000 (BP-2), \$1,100 (PS-3)

bryston.com

If you are the least bit familiar with Bryston, you know they are all about power. Their new solid-state BP-2 MM/MC phonostage (also available as MM only) is musical and dead quiet, even more so with their external PS-3 power supply. The mini stack of both, are small enough to fit on your rack next to your turntable and will stun you with their performance. We'll have all the details, with and without power supply shortly, on our Cartridge Dude website.

You already own the music.
You might as well hear all of it.

Contact The Sound Organisation
today for your closest retailer.



rega

ProAc
perfectly natural

Quadraspire

THE
CHORD™
COMPANY

BRYSTON

hii
Face the Music

support@soundorg.com
(972) 234-0182
soundorg.com

The
s)und
Organisation

Future Tense

Reviews in our immediate future...



The Conrad-Johnson HVA1

\$7,500

conradjohnson.com

Though Conrad-Johnson is new to the world of headphones, they've been building world class vacuum tube electronics for 40 years. If you can imagine a GAT preamplifier for headphones, this is it. Priced at the premium end of the scale, a look inside the enclosure reveals all the same bits under the hood of their flagship GAT. We are running this one through its paces with a number of headphones, looking for the limits of its performance.

The sound and vision of Scandinavia



Prisma provides multi-room/multi-zone connectivity and control for playback of stored and streamed media, wired or wireless, all managed from a mobile device through a dedicated system control app.

In addition to Bluetooth®, AirPlay, and Spotify Connect, Prisma features Chromecast built-in, a unique streaming portal allowing effortless direct connection to hundreds of streaming applications, including Roon, TIDAL, Qobuz, Deezer, Google Play Music, and TuneIn radio, for the best possible performance and user experience.

Initially available in the new I15 Prisma integrated amplifier, I35 Prisma integrated amplifier, and CD35 Prisma CD player – with more to come.

► For more on all our new Primare models go to primare.net

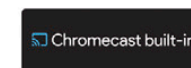

Authorized North American Distributor

MOFI DISTRIBUTION

mofidistribution.com

Future Tense

Reviews in our immediate future...



Nagra Tube DAC

\$19,999

nagraaudio.com

Nagra's new Tube DAC can almost be considered a compact version of their top HD DAC, utilizing decoding circuitry capable of decoding DSD256 files, for the ultimate in resolution. As the name implies, it's full tube output stage adds another level of delicacy, up from their popular Classic DAC, though it resides in a form factor similar to the Classic series of components. We are working feverishly on a full review of this, and the entire Classic series.

Welcome to The Iron Age.

Introducing Jern Speakers

jernspeakers.com





www.francoserblin.it

Future Tense

Reviews in our immediate future...



Bowers & Wilkins Formation Suite
Formation Duo (\$3,999/pair), Formation Sub (\$999)
bowers-wilkins.com

Legendary speaker manufacturer Bowers & Wilkins delivers premium wireless with the Formation Suite. Combining technologies from their 700 and 800 series along with a new enclosure, housing a pair of 125 watt amplifiers for the woofer and tweeter, the Formation speakers are as powerful as they are visually stunning.

An on board DAC handles files to 24bit/96kHz, and the on board DSP promises solid bass down to 25hz, easily augmented by the Formation Sub. Watch for our full review shortly.

Future Tense

Reviews in our immediate future...



Falcon Acoustics LS3/5A speakers

\$3,295/pair

mofidistribution.com

There have been many variations on the LS3/5a theme. Some subtle, some major, but after all these years, the speaker that started the mini monitor craze, proving that great sound can come from a small box is still alive and well. The current version from Falcon Acoustics, under the watchful eye of Malcolm Jones, the designer of the original KEF B110 and T27 from the original version.

We've always been a fan and have experienced quite a few versions of the LS3/5a, but these are the best yet.

New level of sonic performance
Master-quality sound.

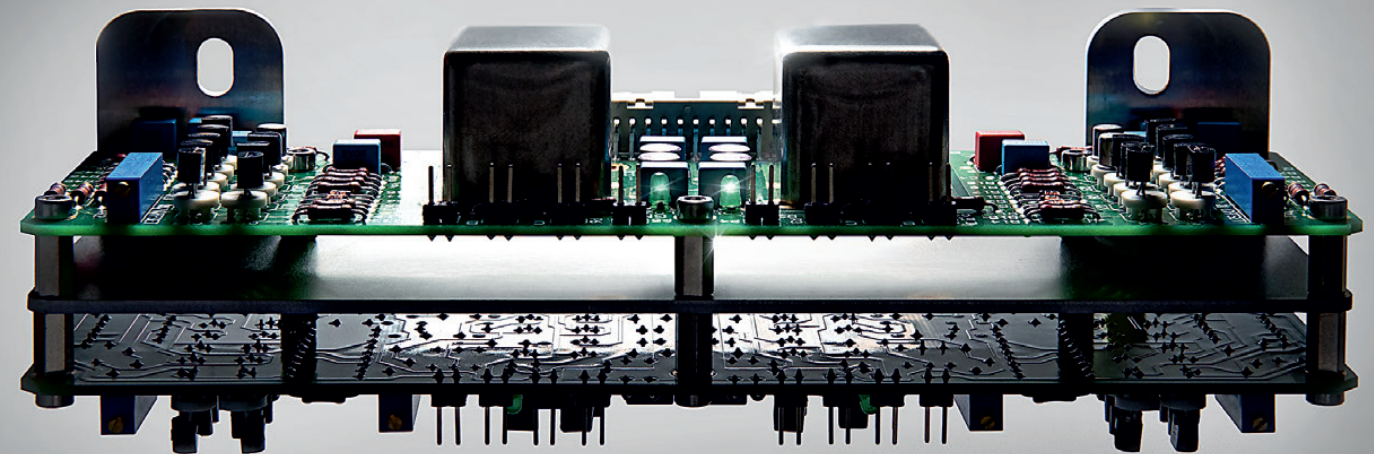

Formula xHD | new upgrade analog module rev. 2



Playlist:

What Our Readers Are Into

Tone Playlists are sponsored by...

qobuz

Stevie Wonder—Pastime Paradise

Air—Run

Trombone Shorty—Buckjump

John Martyn—Glory Box

George Michael—Brother Can You Spare a Dime?

David Gray—Sail Away

Jamie Woon—Forgiven

Gregory Porter—God Bless The Child

Fink—Trouble's What You're In

London Grammar—Hey Now



Qobuz' own David Solomon was kind enough to give us a playlist a few issues ago, and it was over 50 tracks! That's a true-blue music guy. So we posted ten of them and they've been so well liked, a number of readers have emailed asking if we'd publish the rest. So, here's ten more of Dave's faves...



CLEARAUDIO

HIGH END | MADE IN GERMANY



CONCEPT WOOD



JUBILEE MM



PERFORMANCE DC WOOD

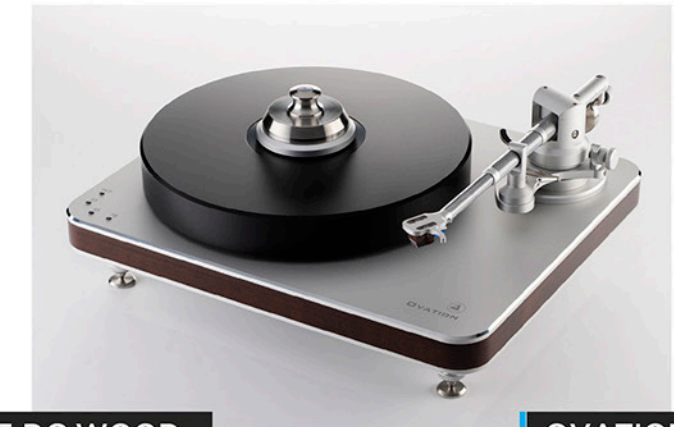

OVIATION



INNOVATION



JUBILEE MC



MINE: it should be yours

RUN D.M.C. — The Singles

About \$100

Amazon.com

If you really want to rock it like that, you might need to search a bit. This Record Store Day release from a few years ago is starting to fetch a higher price all the time. Last time we checked, these were selling for about \$60. This special part of hip-hop's past needs to be part of your collection if you're a true believer. It's tricky.



Where Have all the Good Stereos Gone?



We know. Sorting through the jungle that is pre-owned hi-fi gear can be tough. Myriad Internet forums and online shopping sites just don't offer the expertise required to make sound decisions.

That's where Echo Audio comes in. We have more than 20 years of retail experience in selling hi-fi equipment the way it should be sold: In a brick-and-mortar environment that provides you with personalized attention.

While we will certainly ship any of our gently used classics directly to your door, we invite you to stop by our shop in beautiful downtown Portland, Oregon to browse our inventory in person. Thanks to an in-house service department, we not only service everything we sell, but every piece of used gear is thoroughly checked before being put on display. Consider our white-gloves treatment your guarantee against potential problems.

So, when you are looking for high-quality, lightly used hi-fi gear, look no further than Echo Audio. Be sure to check out our Web site for current products and new arrivals.

echo)))
audio

www.echohifi.com 888.248.echo

Dealers That Mean Business:

You've read all the reviews, you've argued with the internet pundits,

and you're ready to write a check. Now what? If you're a slightly used customer that likes to shop for the best bargain you can find on Audiogon, this article is not for you. Controversial though it might sound, I'm not against Audiogon. If you want a gently pre-owned preamp, love music, and just don't want to buy new, I get that - so long as you know what you're getting into. Audiogon can be a great place to buy pre-owned gear if you know exactly what you want - and don't expect ANY service. But someone must buy it new, so you can buy it used- remember that!

If you are the customer that likes to buy new, loves the feel (and the smell) of taking it out of the box for the first time, knowing no one else has touched it, I get that too. Personally, I'm about 50/50 on this experience, as I am with cars. Ask anyone who's bought a preamp or a used car from me, it's usually been pampered.

However, if you are going to spring for new gear, you need a good dealer. Someone who understands you, your music and most of all your perspective. You need someone to help you find the right components that will work together as a system, help you set it up in some cases, and offer support when things don't work out as planned. There's no substitute for experience, and a great dealer knows their products, and knows what will work best for you.

Nearly every audio system that has failed to achieve the greatness expected of it can be traced back to poor component choice (system and/or room) synergy and poor component setup. I've been to hifi shows, homes, and dealers all over the world - hearing sound good, bad, and somewhere in between. It always boils down to these two factors if something isn't truly broken, and it rarely is.

The solution is easy. Find a great dealer. While there isn't a hifi shop on every corner like there was back in the 70s, there are still some truly great dealers out there that will help you put together a stunning music system, regardless of your budget. And I'm on a mission to find as many of them as I can for you.

I'm starting with the folks I know, in this new section of the magazine. Most of the establishments in this list are running full page ads in the magazine - and there is a caveat. I will not accept advertising in this magazine from a dealer unless I've been to their place, seen the shop and have talked to a cross section of their customers to know they provide superior service. In most cases, these are hifi shops that I, or someone on the staff has purchased gear from as well.

These are not just people wanting to buy space in TONEAudio. Every one of these dealers carry my personal endorsement, and I hope that will help you on your journey. As we go forward, look for the "TONEAudio Approved Dealer" sticker on your favorite establishment. Know a great dealer, that you've had superior service from? Let me know, I would like to pay them a visit and add them to the list.



HDPREAMP
WINNING AWARDS

BEST SOUND OF 2018 MUNICH HIGH END SHOW



NAGRA

nagraaudio-hd.com • contact us at (800) 813-1663 • rene.laflamme@nagraaudio.com

US dealers: The Audio Salon, Santa Monica CA | Audio Salon, Miami FL | David Lewis Audio, Philadelphia PA | EarsNova, New York NY
David Michael Audio, Detroit MI | Don Better Audio, Cleveland OH | Goodwin's High End, Boston MA | JS Audio, Washington DC
Musical Artisans, Chicago IL | Music Lovers, San Francisco CA | Ne Plus Ultra, Austin TX | Arizona Hi-Fi, Phoenix AZ
Canada dealers: Audio Eden, Toronto ON | Element Acoustics, Vancouver BC | Filtronique, Montreal QC

Dealers That Mean Business: LISTINGS

Austin, Texas: Whetstone Audio

2401 E 6th St. #1001
Austin, Texas 78702

512.477.8503

whetstoneaudio.com



Portland, Oregon: Stereotypes Audio

1401 SE Morrison Street, Suite 115
Portland, Oregon 97214

503.280.0910

stereotypesaudio.com



3000 SERIES SUBWOOFERS

Reference Subwoofer Performance Hits New Lows.

Room-shaking output, subterranean low frequency extension and pinpoint control at a breakthrough price.

New 13-inch high-excursion SVS driver with flat edge wound split-wind voice coil generates seat-shaking bass with unerring accuracy and crisp speed in transients.

Sledge STA-800D2 Amplifier with fully discrete MOSFET output rated at 800 watts RMS, 2,500+ watts peak power unleashes massive amounts current to fully maximize on the potential of the robust 13-inch SVS driver.

Groundbreaking SVS Subwoofer Smartphone App manages volume and custom presets for one-touch tuning for movies, music and more. Also controls parametric EQ, low pass filter, phase, polarity, room gain, port tuning (PB-3000 only) and more.



— Critics agree, 3000 Series subwoofers deliver unrivaled performance. —

"Even at reference levels, the subwoofer didn't break a sweat—each bass note hit with power, precision, and speed. I was completely blown away by my experience. It has no equal at its price."

-Sound & Vision

"Refinement and musicality that is genuinely excellent but still delivers seismic levels of low frequency energy."

-AVForums

"The bass I heard bordered on the difficult to believe -- very fast, very tight, very deep, with more than enough output to fill my room with sound-pressure levels that would satisfy the most demanding bass heads."

-Soundstage



Learn more at SVSound.com





STORIED SOUND FOR EVERY MOMENT.

THE NEW 600 SERIES

Bowers & Wilkins

In House

The soundtrack of assembling the issue...



Legrand Jazz
Michael Legrand

There are numerous pressings of this jazz classic, but this is the one you want, on Impex Records. Nothing is better for deadline stress, than an adult beverage and a great jazz title.

Dealers That Mean Business: LISTINGS

Sarasota, Florida: Suncoast Audio

7353 International Place, Unit 309
Sarasota, Florida 34240

941.932.0282

suncoastaudio.com



New York City, New York: Noho Sound & Stereo

62 Cooper Square
New York, New York 10003

nohosound.com



Cardas Audio

Established 1987



*Iridium
Power*



*Iridium
Interconnect*



*Iridium
Phono*

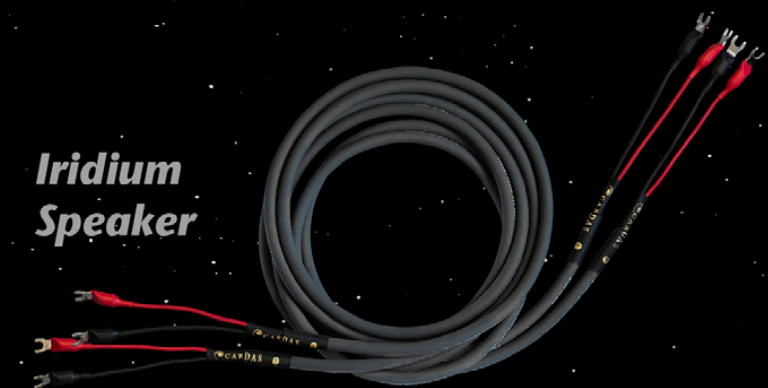

*Iridium
Speaker*

www.cardas.com

PASS

Enjoy the Experience



PASS

Pass Laboratories
13395 New Airport Rd. Ste G., Auburn, CA 95602
(530) 878-5350 - www.passlabs.com

Dealers That Mean Business: LISTINGS

Wauwatosa, Wisconsin: Ultra Fidelis

7125 West North Avenue
Milwaukee, Wisconsin 53213

414.221.0200

ultrafidelis.com



Portland, Oregon: Echo Audio

1015 SW Washington Street
Portland, Oregon 97205

888.248.3246

echohifi.com



Dealers That Mean Business: LISTINGS

Marietta, Georgia: The Audio Company

146 South Park Square NE
Marietta, Georgia 30060

770.429.0434

theaudioco.com



San Diego, California: Deja VU Audio West

4848 Ronson Ct. Ste E
San Diego, California 92111

858.412.4023

dejavuaudiowest.com



WARWICK 
ACOUSTICS



DESIGNED TO AMAZE

The Sonoma Headphone System from Warwick Acoustics.
Nine awards in twelve months, isn't it time you gave them a listen?



www.warwickacoustics.com/headphones

Sonoma™ and its logo are trademarks of Super Audio Center, LLC, Colorado, USA and are used under license.

Dealers That Mean Business: LISTINGS

Morton Grove, Illinois: Quintessence Audio

5701 W. Dempster Street
Morton Grove, Illinois 60053

847.966.4434

quintessenceaudio.com



Scottsdale, Arizona: LMC Home Entertainment

15507 N. Scottsdale Road, Suite 135
Scottsdale, Arizona 85254

480.403.0011

Lmche.com



Setting the record straight since 1978.
40 years of American craftsmanship
from our family to yours!



Vancouver, Canada: HiFi Centre

433 Carrall Street
Vancouver, BC V6B 6E3

888.232.9995

hificentre.com



Gig Harbor, Washington: Gig Harbor Audio

3019 Judson St. Suite D
Gig Harbor, Washington 98335

253.228.6021

gigharboraudio.com



Responds naturally to you



Wireless adaptive noise cancellation



Smart power with a 22-hour battery life

Bowers & Wilkins

bowers-wilkins.com

In House

The soundtrack of assembling the issue...

Superfly, the Soundtrack Curtis Mayfield

Who says SACD is dead? MoFi's latest recreation of this 70s masterpiece will get you up and out on the street in no time. And seeing the issue is done, it's time to party.

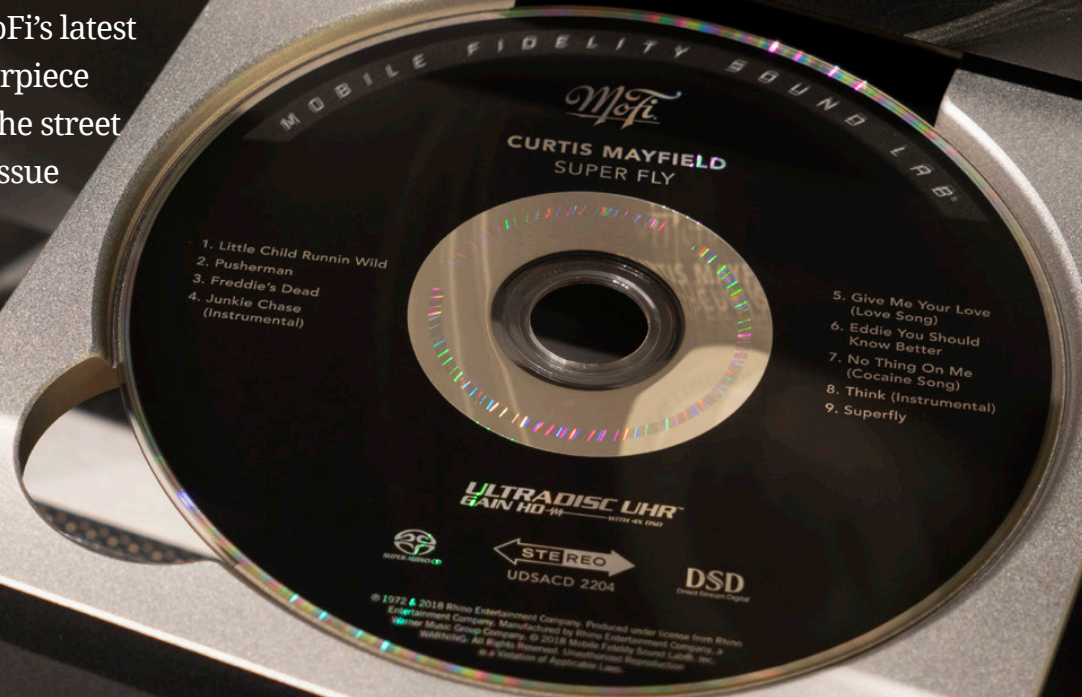

PrimaLuna®

Music Illuminated™

"PrimaLuna's DiaLogue Premium HP is an integrated amplifier whose sound quality approaches that of pairings of reference Class A preamps and power amps. PrimaLuna has another winner"

— Robert Deutsch, *Stereophile*



\$4399

DiaLogue Premium HP Integrated Amplifier

The finest tube integrated at any price. Any.

All four PrimaLuna components reviewed by *Stereophile* are rated Class A, meaning *the best without regard to cost*.

- ProLogue Premium Integrated \$2399
- DiaLogue Premium Integrated \$3399
- DiaLogue Premium HP Integrated (pictured) \$4399
- Award-winning preamps and poweramps also available

PrimaLuna has won more Editors' Choice Awards from *The Absolute Sound* than any other brand.



Go to primaluna-usa.com to get an inside look at our products. You will understand why critics around the world say PrimaLuna makes the best-engineered, best-built, and best-sounding components you can buy at any price. info@primaluna-usa.com 909.931.0219

Playlist:

What Our Readers Are Into

Tone Playlists are sponsored by...

qobuz

The Flaming Lips—Dark Star

Dead Heart—Phosphorescent

Curtis Amy—Gone Into It

Spoon—All The Pretty Girls Go To The City

Jonathan Richman—That Summer Feeling

Lucinda Williams—Born To Be Loved

Stucky Jackson & The Boys—T.V. Child

Cass McCombs—Sleeping Volcanos

Charlie Crockett—The Lost Highway

The Cookers—Ladybugg



Our newest contributor Jessica Sieracki, is a confessed hifi, music, and car nut. When she's not on the track, she's known to spend time with our pals at Gig Harbor Audio. Here's ten of her current tracks that are getting a lot of play...

FOCAL
LISTEN BEYOND

SPECTRAL 40TH



To celebrate our 40th anniversary, we imbued some of our most cutting-edge technology into a classic blast from the past...

This three-way bass-reflex loudspeaker perfectly represents our pioneering heritage of research, design, and expertise.

Like its illustrious Focal predecessors from the 90s - Futura Antea and Spectral 913.1 - Spectral 40th flaunts its signature yellow K2 drivers, updated to take advantage of our current expertise. This new model comprises a next-generation M-profile inverted-dome tweeter, extremely resilient and highly-dynamic speaker cones, a carefully designed crossover with meticulously selected components, a Powerflow™ port, and finished in a beautiful 40th Anniversary Walnut cabinet with a High-Gloss Black two-inch baffle. The well-dampened MDF cabinet features an entirely non-parallel network of partitions and bracings to prevent and dissipate virtually all vibration distortions.

Spectral 40th honors the world of High Fidelity with vibrant, expressive sound at any volume level, regardless of the musical genre, providing hours of listening pleasure.

MADE IN
FRANCE

Last Word

Our parting thought to ponder.



GRAND PRIX AUDIO Monaco Turntable v2.0

A new achievement in analog



"Let the record state that this is the finest turntable I've experienced, at any price."

-Jeff Dorgay, Tone Publications

Music deserves innovation

www.grandprixaudio.com



Socially Speaking

TONEAudio's Online hangouts

If you want more TONE all the time, we're doing our best to disperse more content all of the time on numerous platforms. Just click here to follow us on our main Facebook page:

<https://www.facebook.com/TONEPUB2/>

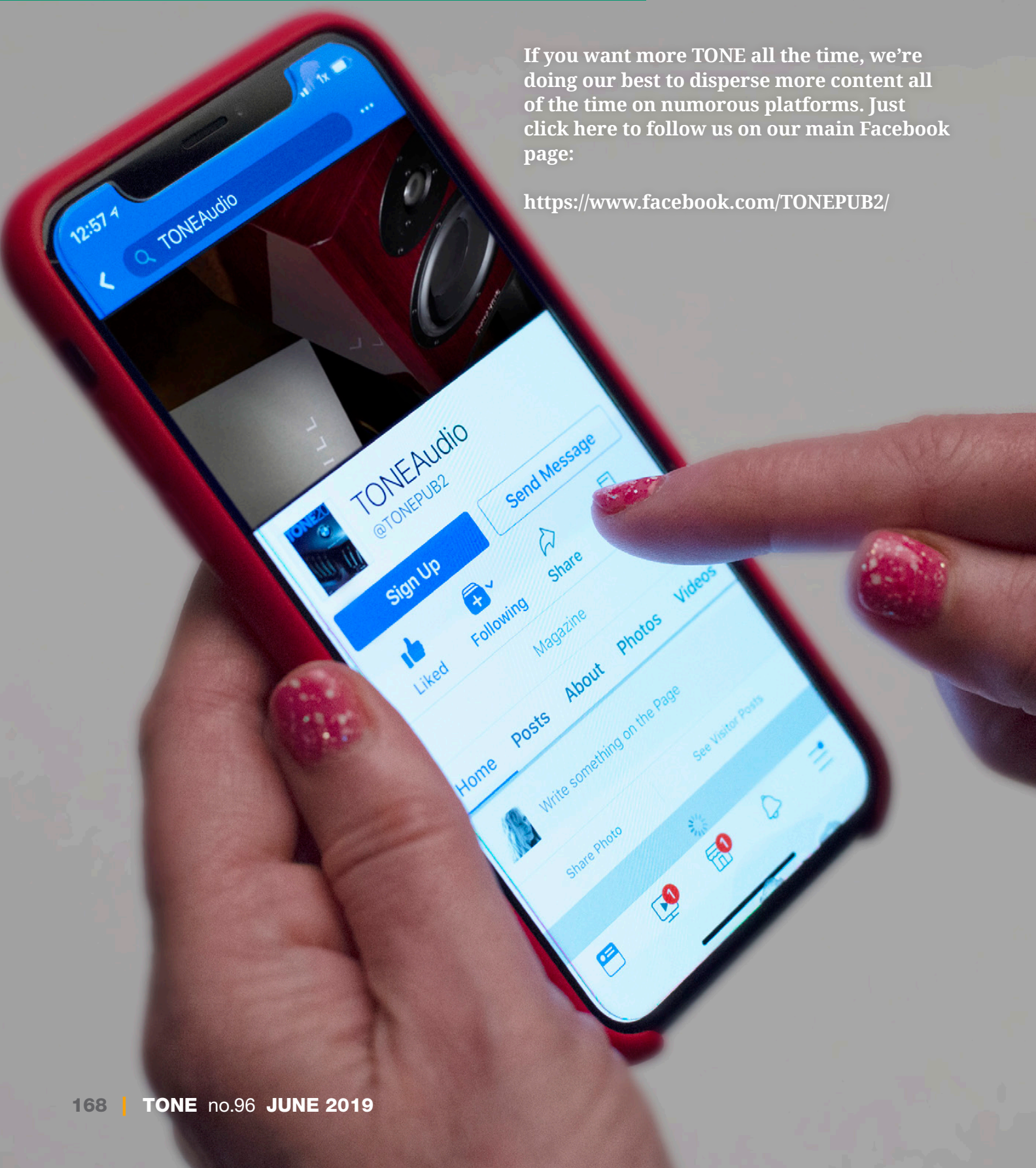
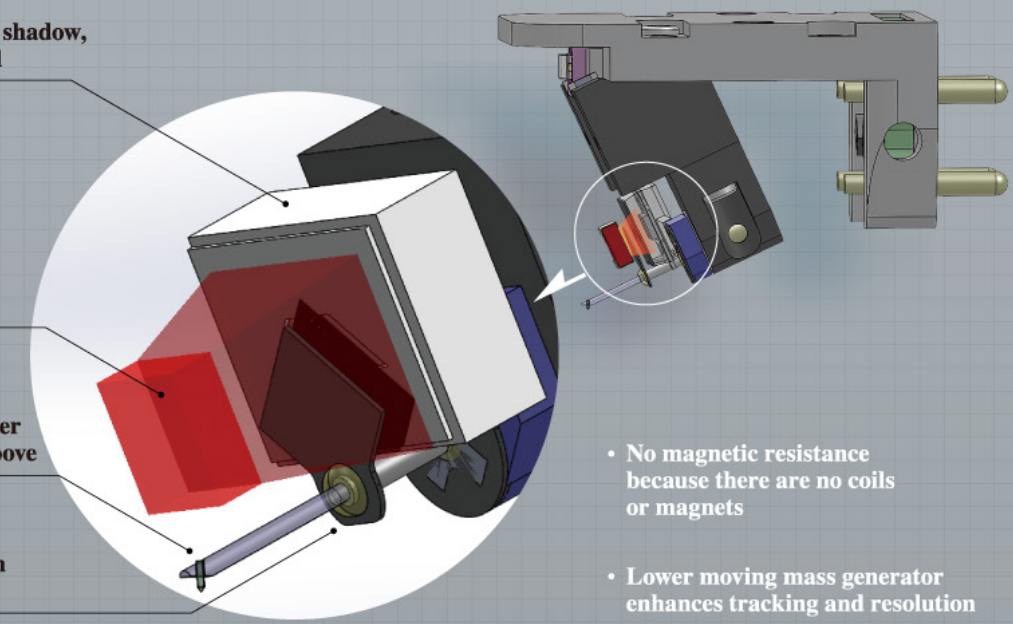

Photo diode detects light and shadow, converting to electrical signal

LED Light source

Stylus/cantilever moves shutter when tracking the record groove

Shutter modulates light beam by stylus movement



• No magnetic resistance because there are no coils or magnets

• Lower moving mass generator enhances tracking and resolution

DS Audio Phono Cartridges

Pure Analog

No Lasers

Not Digital

It's Got a Needle

Internationally
Acclaimed & Award
Winner

Handmade in Japan

DS Audio

MUSICAL
SURROUNDINGS

AudioVision
san francisco

welcome to the hifi show



AUDIOVECTOR

Handmade in Denmark since 1979



Inspiring Loudspeakers that are designed
to be easily placed in any room!

from less than \$1500 a pair and up

1628 california st. (on the cable car line)
san francisco, california 94109

www.audiovisionsf.com

abyss
alta audio
audeze
audio physic
audiovector
dali
davone
dynaudio
elac
focal
gallo
gamut
grado
hifiman
jl audio
kef
mrspeakers
psb
raidho/scansonic
rel acoustics
triangle
warwick acoustics
wilson benesch
yg acoustics

anthem
antipodes
arcam
astell & kern
atoll
audioquest
bel canto
bluesound
cardas
chord electronics
clearaudio
crystal cable
deq
devialet
dr. feickert
eat
funk firm
h.r.s.
ifi
integra
kiseki
lyngdorf audio
lyra
marantz
margules
mcintosh
moon by simaudio
nad
naim audio
nordost
nuforce
octave
ortofon
pear audio
primaluna
pro-ject
ps audio
quad
quadraspire
rega
shinola
sme
sonos
soundsmith
stillpoints
technics
unison research
woo audio

Get The Gear: Where to find what you've seen in this issue.

Abyss	abyss-headphones.com	Bryston	bryston.com
Ana Mighty Sound	anamightysound.com	Cardas Audio	cardas.com
Analog Magik	analogmagik.com	Chord Cable	soundorg.com
Anthem	anthemav.com	Clearaudio	musicalsurrroundings.com
Aqua Audio	aquahifi.com	conrad-johnson	conradjohnson.com
Atlas Cable	integrityhf.com	dCS	dcsltd.co.uk
Audia Flight	audioluxllc.com	Dynaudio	dynaudio.com
Audio Classics	audioclassics.com	E.A.T.	vanaltd.com
Audio Physic	vanaltd.com	Echo Audio	echohifi.com
Audio Research	audioresearch.com	Esoteric	esoteric-usa.com
Audio Solutions	highendbyoz.com	Exogal	exogal.com
AudioVision SF	audiovisionsf.com	Focal	audioplusservices.com
Audolici	audolici.com	Franco Serblin	francoserblin.it
AVID HiFi	avidhifi.com	Gold Note	goldnote.it
Boulder	boulderamp.com	Golden Ear	goldenear.com
Bowers & Wilkins	bowers-wilkins.com	Grand Prix Audio	grandprixaudio.com

T H E F I N E A R T S

In celebration of 40 years in the pursuit of high-performance in audio, conrad-johnson is pleased to present our new limited production ART150 (stereo 150 Watts/channel) and ART300 (mono 300 Watts) amplifiers, each a virtual window on the emotional experience of live music right in your home.



conrad-johnson It just sounds right.
2800K Dorr Ave • Fairfax, VA 22031 • phone: 703-698-8581, fax: 703-560-5360 • www.conradjohnson.com

Get The Gear: Where to find what you've seen in this issue.

Hana Cartridges	musicalsurrroundings.com	PrimaLuna	primaluna-usa.com
HiFi Centre	hificentre.com	Primare	mofielectronics.com
Jern Speakers	jernspeakers.com	ProAc	soundorg.com
Kanto Audio	kantoaudio.com	ProJect	pro-jectusa.com
Kiseki	kisekiusa.com	REL	rel.net
Linn Audio	linn.co.uk	Rega	soundorg.com
Luxman	luxman.com	Simaudio	simaudio.com
McIntosh	mcintoshlabs.com	Sonus faber	sonusfaber.com
MartinLogan	martinlogan.com	SVS Subwoofers	svsound.com
MoFi Electronics	mofielectronics.com	Tellurium Q	telluriumq.com
Musical Fidelity	audioplusservices.com	Totem	totemacoustic.com
Nagra	nagraaudio.com	Upscale Audio	upscaleaudio.com
Naim	Audioplusservices.com	VAC	vac-amplifiers.com
Octave	octave.de	Vitus Audio	highendbyoz.com
PS Audio	psaudio.com	VPI	vpiiindustries.com
Paradigm	paradigm.com	Warwick Acoustics	warwickacoustics.com
Pass Labs	passlabs.com		

Coming in issue **no.97**

- **Tubes, Tubes, Tubes...**
- **Prima Luna EVO 400 Amplifier and Pre**
- **BAT VK-56SE Power Amplifier**
- **Audio Research REF 160M Monoblocks**
- **And more...**

"...these things sound just as elegant as they look.
Or is it, they look just as elegant as they sound?
Either way, the results are genuinely impressive."
High Def Digest



Sonus faber

Aida
LIMITLESS IMMERSION

sonusfaber.com

Beneath its timeless aesthetic and familiar curves, the new Aida has been completely overhauled. Years of tireless research and refinement have yielded a pristine electroacoustic engineering project featuring all-new drivers, crossovers and internal structuring. A dramatic improvement upon the speaker once called "as close to perfection as I have ever experienced."

